

Submarine Power Cables

Submarine Power Cables

Since decades Nexans' plant in Hannover is specialised in the design, production and installation of low and medium voltage submarine power cables required for river or lake crossings, power supply to islands and platforms for offshore oil and gas production and offshore wind mill parks.

Numerous successfully completed projects with our cables in Europe and overseas have proven the capability of Nexans' highly skilled technical staff to cope with submarine cable design, production, transportation and laying problems.

The experience gained by Nexans in the development of extra high voltage cables is further applied in the production of submarine power cables.



High voltage laboratory, partial discharge measurement and ac voltage test

The properties of cross-linked polyethylene (XLPE) and ethylene propylene rubber (EPR) insulated cables

Cross linked polyethylene and EPR have proven as excellent cable insulating compounds for submarine power cables. The main reasons are the outstanding electrical and mechanical properties of these materials. Compared to oil filled paper insulated submarine cables, XLPE and EPR insulated cables offer the following advantages:

- XLPE and EPR are solid dielectrics. They are maintenance free, no supervision and control of the oil level in the cable systems is necessary.
- XLPE and EPR insulated submarine power cables are usually supplied without

a lead sheath. Their construction is therefore of lighter weight permitting longer continuous delivery lengths and easier handling during transportation and laying. The bending radius is small. The solid dielectric and the heavy steelwire armouring are superior to the paper insulated and lead sheathed cables and are much less sensitive to severe stresses to which submarine cables are subjected during transportation, laying and operation.

- The main electrical and mechanical characteristics of XLPE and EPR insulated medium voltage cables compared with paper-oil-insulated cables, are shown in table 1.



Cable laying within an offshore windfarm

	Dielectric loss factor $\tan\delta$	Dielectric constant ϵ_r	Insulation resistance	Operating temperature	Short circuit temperature
XLPE	0,0004	2,3	$10^{17} \Omega \cdot \text{cm}$	90°C	250°C
EPR	0,002	3	$10^{14} \Omega \cdot \text{cm}$	90°C	250°C
Paper-oil	0,003	3,7	$10^{14} \Omega \cdot \text{cm}$	60-70°C	140-170°C

Table 1

Testing

Testing at the factory is done according to the specified national or international standards and furthermore in strict accordance to the rules of the Nexans quality assurance recommendations.

Modern testing facilities permit extensive testing of the cables as: routine tests - special tests - type tests.

Transportation, Laying, Field testing

Special manufacturing, storing and loading facilities for submarine power cables in long lengths have been developed at Nexans including the necessary provisions for transportation to seaports and direct transfer to cable laying ships or to special loading platforms. Short lengths are supplied on special cable drums, while longer lengths are normally supplied in coils laid out on platforms or fed directly into the cable laying ship.

For the actual cable laying operation, platforms can be placed by means of a floating crane on barges or supply boats. The cable is then laid directly from the coil into the water through a roller system

assistance and supervision of the cable laying operation or do the installation on turnkey basis including substations and cable protection equipment.

The machinery and equipment for cable laying as well as cable accessories, such as specially developed splicing kits for submarine joints and cable terminations, can also be provided.

Cable testing after installation and in case of a damage fault location with modern measuring equipment can be performed by Nexans as well.



Lifting a submarine power cable drum for Abu Dhabi



Transfer of a submarine cable into a laying vessel



Loading of a flat containing 500 tons of submarine cables for China

which is necessary to avoid kinking. For laying the cable into deeper water a special cable laying unit which coordinates the laying speed and braking of the cable is required. Depending on the possible danger of damages by anchors or heavy fishing gear, the cable is either laid directly on the bottom or buried in the seabed using a water jet stream or other trenching methods. On request, Nexans can either provide technical



Capjet burying equipment in operation

Design of medium voltage submarine cables

Nexans supplies different types of submarine power cables depending on specific requirements and conditions at site. The cable constructions are based on the mayor national or international Standards e.g. VDE, IEC and ICEA or according to customers design and standards.

The Nexans Group has produced submarine power cables up to 525 kV A.C. with paper-oil insulation; our plant in Hannover is specialised in the production of submarine power cables with XLPE and EPR insulation up to 36 kV.

Medium-voltage submarine cable, including fibre optic cable

Typical design of a medium-voltage submarine cable with a maximum voltage up to 36 kV, including fibre optic cable.

Type: 2XS(FL)2YRAA

1. Conductor: copper, circular stranded compacted
2. Conductor screening: extruded semi-conductive compound
3. Insulation: XLPE
4. Insulation screening: extruded semi-conductive compound
5. Screen: copper wires and copper helix, swelling powder
6. Laminated sheath: aluminium tape bonded to overlaying PE sheath
7. Fibre optic cable, optional
8. Fillers: polypropylene strings
9. Binder tapes
10. Bedding: polypropylene strings
11. Armour: galvanized round steel wires
12. Serving: bituminous compound, hessian tapes, polypropylene strings with coloured stripe



Medium-voltage submarine cable, XLPE insulated

Typical design of a medium-voltage submarine cable with a maximum voltage up to 36 kV

Type: 2XS2YRAA

1. Conductor: copper, circular stranded compacted, longitudinal water-tight by filling with a sealing compound (optional)
2. Conductor screening: extruded semi-conductive compound
3. Insulation: XLPE
4. Insulation screening: extruded semi-conductive compound
5. Screen: copper tapes
6. Separator: plastic foil
7. Sheath: PE
8. Fillers: polypropylene strings
9. Binder tapes

10. Bedding: polypropylene strings
11. Armour: galvanized round steel wires
12. Serving: hessian tapes, bituminous compound, polypropylene strings, lime wash



Medium-voltage submarine cable, EPR insulated

Typical design of a medium-voltage submarine cable with a maximum voltage up to 36 kV

Type: 3GSERAA

1. Conductor: copper, circular stranded compacted, longitudinal water-tight by filling with a sealing compound (optional)
2. Conductor screening: extruded semi-conductive compound
3. Insulation: EPR
4. Insulation screening: extruded semi-conductive compound
5. Screen: copper tapes
6. Fillers: polypropylene strings

7. Binder tapes
8. Bedding: polypropylene strings
9. Armour: galvanized round steel wires
10. Serving: hessian tapes, bituminous compound, polypropylene strings, lime wash

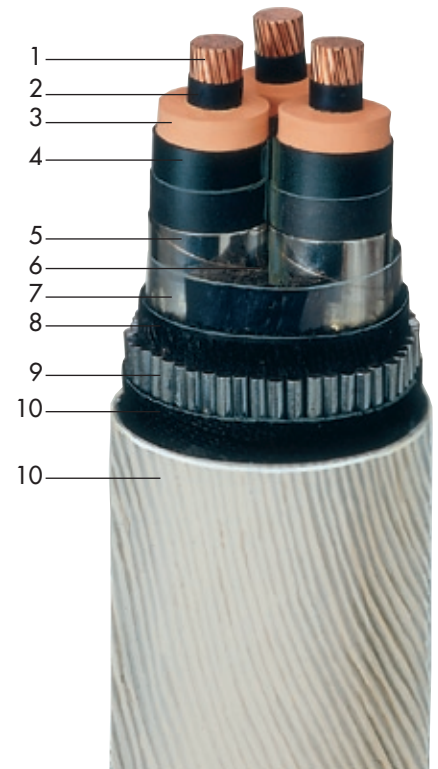

Cable Data XLPE

These constructional and electrical data are values of typical submarine cables up to 36 kV (Standard IEC), with radial and longitudinal water barrier.

- 1 Conductor
- 2 Conductor screening
- 3 XLPE insulation

- 4 Insulation screening
- 5 Metal screen and sealing
- 6 Laminated core sheath
- 7 Fillers, FO cables
- 8 Binder tapes
- 9 Bedding
- 10 Armour
- 11 Serving

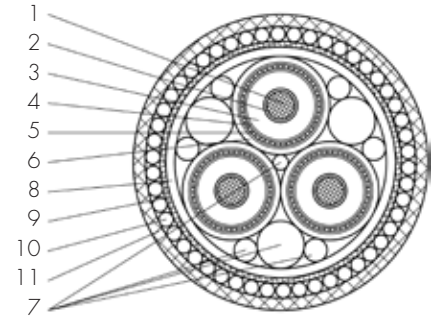

Legend for tables

Constructional Data

- 1, 2, 3, 4, 5, – Nominal values
- 6, 7, 8
- 9, 10, 11 – Approx. values

Electrical Data

- 1 – Nominal value
- 2 – Max. value to IEC 60228
- 3, 4, 5, 6, 9 – Approx. values
- 7 – Calculated in accordance to IEC publications 60287 and the following assumptions
 - Max. conductor temperature at continuous load 90°C
 - Frequency 50 Hz
 - Max. ambient temperature 20°C
 - Screens bonded at both ends and connected to earth
 - burrial depth of cables 1.0 m
 - Thermal resistivity of surroundings 1.0 K·m/W
 - at current acc. to 7

8

Constructional Data, Electrical Data

2XS(FL)2YRAA 6/10(12) kV

Constructional Data

1	2	3	4	5	6	7	8	9	10	11
Nominal cross sectional area of conductor (mm ²)	Conductor copper round stranded diameter over conductor (mm)	Insulation XLPE wall thickness (mm)	Screen copper wires and counter helix cross sectional area (mm ²)	Metallic tape aluminium wall thickness (mm)	Core sheath PE black wall thickness (mm) diameter (mm)	Bedding wall thickness (mm)	Armour steel wires round galvanized diameter (mm)	Serving bitumen fib. material and lime wash wall thickness (mm)	Outer diameter of cable (mm)	Cable weight (t/km)
35	7.0	3.4	16	0.2	2.5 24	2	3.15	3.5	70	7.5
50	8.2	3.4	16	0.2	2.5 25	2	3.15	3.5	73	8.2
70	9.9	3.4	16	0.2	2.5 27	2	4.0	3.5	77	9.9
95	11.5	3.4	16	0.2	2.5 28	2	4.0	3.5	80	11.1
120	13.0	3.4	16	0.2	2.5 30	2	4.0	3.5	84	12.2
150	14.5	3.4	25	0.2	2.5 31	2	4.0	3.5	87	13.6
185	16.1	3.4	25	0.2	2.5 33	2	5.0	4.0	93	16.8
240	18.6	3.4	25	0.2	2.5 35	2	5.0	4.0	99	19.1

2XS(FL)2YRAA 6/10(12) kV

Electrical Data

1	2	3	4	5	6	7	8	9
Nominal cross sectional area conductor (mm ²) screen (mm ²)	Conductor resistance DC 20°C (Ω/km)	Conductor resistance AC 90°C (Ω/km)	Screen resistance 20°C (Ω/km)	Capacitance (μF/km)	Inductance (mH/km)	Current rating (A)	Losses (W/m)	1s short circuit current after full load at 90°C conductor temperature (kA) screen (kA)
35 16	0.524	0.67	1.15	0.23	0.43	167	57	5.0 3.3
50 16	0.387	0.49	1.15	0.26	0.41	199	60	7.1 3.3
70 16	0.268	0.34	1.15	0.29	0.38	241	62	10.0 3.3
95 16	0.193	0.25	1.15	0.32	0.37	288	65	13.6 3.3
120 16	0.153	0.20	1.15	0.35	0.35	327	67	17.1 3.3
150 25	0.124	0.16	0.73	0.38	0.34	363	69	21.4 5.1
185 25	0.0991	0.13	0.73	0.42	0.33	405	71	26.5 5.1
240 25	0.0754	0.10	0.73	0.47	0.32	464	74	34.3 5.1

2XS(FL)2YRAA 12/20(24) kV

Constructional Data

1	2	3	4	5	6	7	8	9	10	11	
Nominal cross sectional area of conductor (mm ²)	Conductor copper round stranded diameter over conductor (mm)	Insulation XLPE wall thickness (mm)	Screen copper wires and counter helix cross sectional area (mm ²)	Metallic tape aluminium wall thickness (mm)	Core sheath PE black wall thickness (mm)	Core sheath PE black diameter (mm)	Bedding wall thickness (mm)	Armour steel wires round galvanized diameter (mm)	Serving bitumen fib. material and lime wash wall thickness (mm)	Outer diameter of cable (mm)	Cable weight (t/km)
35	7.0	5.5	16	0.2	2.5	28	2	3.15	3.5	78	8.8
50	8.2	5.5	16	0.2	2.5	30	2	3.15	3.5	83	9.3
70	9.9	5.5	16	0.2	2.5	31	2	4.0	3.5	87	11.4
95	11.5	5.5	16	0.2	2.5	33	2	4.0	3.5	89	12.7
120	13.0	5.5	16	0.2	2.5	34	2	4.0	4.0	94	14.1
150	14.5	5.5	25	0.2	2.5	36	2	4.0	4.0	97	15.3
185	16.1	5.5	25	0.2	2.5	37	2	5.0	4.0	102	18.6
240	18.6	5.5	25	0.2	2.5	40	2	5.0	4.0	108	21.1

2XS(FL)2YRAA 12/20(24) kV

Electrical Data

1	2	3	4	5	6	7	8	9
Nominal cross sectional area conductor (mm ²) screen (mm ²)	Conductor resistance DC 20°C (Ω/km)	Conductor resistance AC 90°C (Ω/km)	Screen resistance 20°C (Ω/km)	Capacitance (μF/km)	Inductance (mH/km)	Current rating (A)	Losses (W/m)	1s short circuit current after full load at 90°C conductor temperature (kA) screen (kA)
35 16	0.524	0.67	1.15	0.17	0.47	171	60	5.0 3.3
50 16	0.387	0.49	1.15	0.18	0.44	199	60	7.1 3.3
70 16	0.268	0.34	1.15	0.20	0.41	243	63	10.0 3.3
95 16	0.193	0.25	1.15	0.22	0.40	292	67	13.6 3.3
120 16	0.153	0.20	1.15	0.24	0.38	328	68	17.1 3.3
150 25	0.124	0.16	0.73	0.26	0.37	364	70	21.4 5.1
185 25	0.0991	0.13	0.73	0.28	0.35	408	72	26.5 5.1
240 25	0.0754	0.10	0.73	0.31	0.34	467	75	34.3 5.1

2XS(FL)2YRAA 18/30(36) kV

Constructional Data

1	2	3	4	5	6	7	8	9	10	11	
Nominal cross sectional area of conductor (mm ²)	Conductor copper round stranded diameter over conductor (mm)	Insulation XLPE wall thickness (mm)	Screen copper wires and counter helix cross sectional area (mm ²)	Metallic tape aluminium wall thickness (mm)	Core sheath PE black wall thickness (mm)	Core sheath PE black diameter (mm)	Bedding wall thickness (mm)	Armour steel wires round galvanized diameter (mm)	Serving bitumen fib. material and lime wash wall thickness (mm)	Outer diameter of cable (mm)	Cable weight (t/km)
50	8.2	8.0	16	0.2	2.5	35	2	3.15	3.5	93	11.1
70	9.9	8.0	16	0.2	2.5	36	2	4.0	4.0	99	12.8
95	11.5	8.0	16	0.2	2.5	38	2	4.0	4.0	102	14.9
120	13.0	8.0	16	0.2	2.5	39	2	4.0	4.0	105	16.2
150	14.5	8.0	25	0.2	2.5	41	2	4.0	4.0	108	17.6
185	16.1	8.0	25	0.2	2.5	42	2	5.0	4.0	113	21.0
240	18.6	8.0	25	0.2	2.5	45	2	5.0	4.0	119	23.4
300	20.6	8.0	25	0.2	2.5	47	2	4.2	4.0	121	24.1
400	23.8	8.0	35	0.2	2.5	50	2	4.5	4.0	129	28.1
500	26.6	8.0	35	0.2	2.6	53	2.5	5.0	4.0	137	33.4
630	30.6	8.0	35	0.2	2.7	57	2.5	5.0	4.0	145	39.1
800	34.7	8.0	35	0.2	2.9	61	2.5	6.0	4.0	157	48.9

2XS(FL)2YRAA 18/30(36) kV

Electrical Data

1	2	3	4	5	6	7	8	9
Nominal cross sectional area conductor (mm ²) screen (mm ²)	Conductor resistance DC 20°C (Ω/km)	Conductor resistance AC 90°C (Ω/km)	Screen resistance 20°C (Ω/km)	Capacitance (μF/km)	Inductance (mH/km)	Current rating (A)	Losses (W/m)	1s short circuit current after full load at 90°C conductor temperature (kA) screen (kA)
50 16	0.387	0.49	1.15	0.14	0.48	202	62	7.1 3.3
70 16	0.268	0.34	1.15	0.15	0.45	245	65	10.0 3.3
95 16	0.193	0.25	1.15	0.17	0.42	291	67	13.6 3.3
120 16	0.153	0.20	1.15	0.18	0.41	330	69	17.1 3.3
150 25	0.124	0.16	0.73	0.19	0.39	366	71	21.4 5.1
185 25	0.0991	0.13	0.73	0.21	0.38	411	74	26.5 5.1
240 25	0.0754	0.10	0.73	0.23	0.36	470	77	34.3 5.1
300 25	0.0601	0.079	0.73	0.25	0.35	564	83	43.3 5.1
400 35	0.0470	0.063	0.53	0.28	0.34	627	86	57.8 7.1
500 35	0.0366	0.050	0.53	0.32	0.32	699	88	72.2 7.1
630 35	0.0283	0.041	0.53	0.34	0.31	777	92	91.0 7.1
800 35	0.0221	0.034	0.53	0.37	0.30	852	96	115.6 7.1

Cable Data XLPE

These constructional and electrical data are values of typical submarine cables up to 36 kV (Standard IEC).

- 1 Conductor
- 2 Conductor screening
- 3 XLPE insulation

- 4 Insulation screening
- 5 Metal screen and separator
- 6 Core sheath
- 7 Fillers / FO cables
- 8 Bedding
- 9 Armour
- 10 Serving

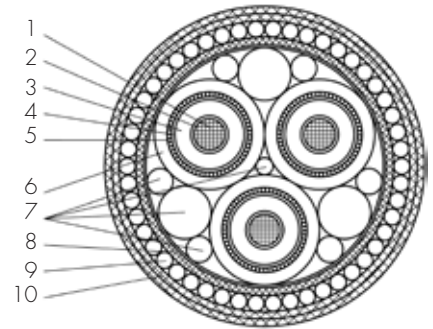

Legend for tables

Constructional Data

- 1, 2, 3, 4, 5, – Nominal values
- 6, 7, 8
- 9, 10, 11 – Approx. values

Electrical Data

- 1 – Nominal value
- 2 – Max. value to IEC 60228
- 3, 4, 5, 6, 9 – Approx. values
- 7 – Calculated in accordance to IEC publications 60287 and the following assumptions
 - Max. conductor temperature at continuous load 90°C
 - Frequency 50 Hz
 - Max. ambient temperature 20°C
 - Screens bonded at both ends and connected to earth
 - burrial depth of cables 1.0 m
 - Thermal resistivity of surroundings 1.0 K·m/W
 - at current acc. to 7

8

Constructional Data, Electrical Data

2XS2YRAA 6/10(12) kV

Constructional Data

1	2	3	4	6		7	8	9	10	11
Nominal cross sectional area of conductor (mm ²)	Conductor copper round stranded diameter over conductor (mm)	Insulation XLPE wall thickness (mm)	Screen copper wires and counter helix cross sectional area (mm ²)	Core sheath PE black wall thickness (mm)	diameter (mm)	Bedding wall thickness (mm)	Armour steel wires round galvanized diameter (mm)	Serving bitumen fib. material and lime wash wall thickness (mm)	Outer diameter of cable (mm)	Cable weight (t/km)
35	7.0	3.4	16	2.5	22	2	3.15	3.5	65	6.3
50	8.2	3.4	16	2.5	23	2	3.15	3.5	68	7.0
70	9.9	3.4	16	2.5	25	2	4.0	3.5	72	8.8
95	11.5	3.4	16	2.5	26	2	4.0	3.5	76	10.0
120	13.0	3.4	16	2.5	28	2	4.0	3.5	79	11.2
150	14.5	3.4	25	2.5	29	2	4.0	3.5	82	12.3
185	16.1	3.4	25	2.5	31	2	5.0	4.0	89	15.5
240	18.6	3.4	25	2.5	33	2	5.0	4.0	94	17.8

2XS2YRAA 6/10(12) kV

Electrical Data

1		2	3	4	5	6	7	8	9	
Nominal cross sectional area		Conductor resistance DC 20°C	Conductor resistance AC 90°C	Screen resistance 20°C	Capacitance	Inductance	Current rating	Losses	1s short circuit current after full load at 90°C conductor temperature	
conductor (mm ²)	screen (mm ²)	(Ω/km)	(Ω/km)	(Ω/km)	(μF/km)	(mH/km)	(A)	(W/m)	conductor (kA)	screen (kA)
35	16	0.524	0.67	1.15	0.23	0.41	166	56	5.0	0.72
50	16	0.387	0.49	1.15	0.26	0.39	196	58	7.1	0.72
70	16	0.268	0.34	1.15	0.29	0.37	240	61	10.0	0.98
95	16	0.193	0.25	1.15	0.32	0.35	287	63	13.6	0.98
120	16	0.153	0.20	1.15	0.35	0.34	325	65	17.1	0.98
150	25	0.124	0.16	0.73	0.38	0.33	364	66	21.4	1.1
185	25	0.0991	0.13	0.73	0.42	0.32	408	68	26.5	1.1
240	25	0.0754	0.10	0.73	0.47	0.30	471	72	34.3	1.1

2XS2YRAA 12/20(24) kV

Constructional Data

1 Nominal cross sectional area of conductor (mm ²)	2 Conductor copper round stranded diameter over conductor (mm)	3 Insulation XLPE wall thickness (mm)	4 Screen copper wires and counter helix cross sectional area (mm ²)	6 Core sheath PE black		7 Bedding wall thickness (mm)	8 Armour steel wires round galvanized diameter (mm)	9 Serving bitumen fib. material and lime wash wall thickness (mm)	10 Outer diameter of cable (mm)	11 Cable weight (t/km)
				wall thickness (mm)	diameter (mm)					
35	7.0	5.5	16	2.5	26	2	3.15	3.5	74	7.6
50	8.2	5.5	16	2.5	27	2	3.15	3.5	77	8.3
70	9.9	5.5	16	2.5	29	2	4.0	3.5	81	10.3
95	11.5	5.5	16	2.5	30	2	4.0	3.5	85	11.5
120	13.0	5.5	16	2.5	32	2	4.0	3.5	88	12.7
150	14.5	5.5	25	2.5	33	2	4.0	3.5	91	13.9
185	16.1	5.5	25	2.5	35	2	5.0	4.0	98	17.2
240	18.6	5.5	25	2.5	38	2	5.0	4.0	103	19.5

2XS2YRAA 12/20(24) kV

Electrical Data

1 Nominal cross sectional area conductor (mm ²) screen (mm ²)		2 Conductor resistance DC 20°C (Ω/km)	3 Conductor resistance AC 90°C (Ω/km)	4 Screen resistance 20°C (Ω/km)	5 Capacitance (μF/km)	6 Inductance (mH/km)	7 Current rating (A)	8 Losses (W/m)	9 1s short circuit current after full load at 90°C conductor temperature (kA) screen (kA)	
35	16	0.524	0.67	1.15	0.17	0.45	168	58	5.0	0.98
50	16	0.387	0.49	1.15	0.18	0.43	199	59	7.1	0.98
70	16	0.268	0.34	1.15	0.20	0.40	243	62	10.0	0.98
95	16	0.193	0.25	1.15	0.22	0.38	290	64	13.6	1.09
120	16	0.153	0.20	1.15	0.24	0.37	329	66	17.1	1.09
150	25	0.124	0.16	0.73	0.26	0.35	368	68	21.4	1.09
185	25	0.0991	0.13	0.73	0.28	0.34	412	71	26.5	1.09
240	25	0.0754	0.10	0.73	0.31	0.33	472	74	34.3	1.45

2XS2YRAA 18/30(36) kV

Constructional Data

1 Nominal cross sectional area of conductor (mm ²)	2 Conductor copper round stranded diameter over conductor (mm)	3 Insulation XLPE wall thickness (mm)	4 Screen copper wires and counter helix cross sectional area (mm ²)	6 Core sheath PE black		7 Bedding wall thickness (mm)	8 Armour steel wires round galvanized diameter (mm)	9 Serving bitumen fib. material and lime wash wall thickness (mm)	10 Outer diameter of cable (mm)	11 Cable weight (t/km)
				wall thickness (mm)	diameter (mm)					
50	8.2	8.0	16	2.5	33	2	3.15	3.5	88	10.0
70	9.9	8.0	16	2.5	34	2	4.0	3.5	93	12.3
95	11.5	8.0	16	2.5	36	2	4.0	3.5	96	13.5
120	13.0	8.0	16	2.5	37	2	4.0	4.0	100	14.8
150	14.5	8.0	25	2.5	39	2	4.0	4.0	103	16.0
185	16.1	8.0	25	2.5	40	2	5.0	4.0	109	19.5
240	18.6	8.0	25	2.5	43	2	5.0	4.0	114	22.0

2XS2YRAA 18/30(36) kV

Electrical Data

1 Nominal cross sectional area conductor (mm ²) screen (mm ²)		2 Conductor resistance DC 20°C (Ω/km)	3 Conductor resistance AC 90°C (Ω/km)	4 Screen resistance 20°C (Ω/km)	5 Capacitance (μF/km)	6 Inductance (mH/km)	7 Current rating (A)	8 Losses (W/m)	9 1s short circuit current after full load at 90°C conductor temperature (kA) screen (kA)	
50	16	0.387	0.49	1.15	0.14	0.46	201	61	7.1	1.09
70	16	0.268	0.34	1.15	0.15	0.43	245	64	10.0	1.09
95	16	0.193	0.25	1.15	0.17	0.41	292	66	13.6	1.09
120	16	0.153	0.20	1.15	0.18	0.40	330	68	17.1	1.45
150	25	0.124	0.16	0.73	0.19	0.38	368	70	21.4	1.45
185	25	0.0991	0.13	0.73	0.21	0.37	413	72	26.5	1.81
240	25	0.0754	0.10	0.73	0.23	0.35	475	75	34.3	1.81

Cable Data EPR

These constructional and electrical data are values of typical submarine cables up to 36 kV (Standard IEC).

- 1 Conductor
- 2 Conductor screening
- 3 EPR insulation

- 4 Insulation screening
- 5 Metal screen
- 6 Binder tapes
- 7 Fillers / FO cables (optional)
- 8 Bedding
- 9 Armour
- 10 Serving

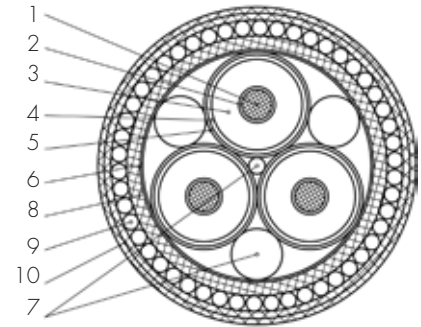

Legend for tables

Constructional Data

- 1, 2, 3, 4, 5, 6 – Nominal values
- 7, 8, 9 – Approx. values

Electrical Data

- 1 – Nominal value
- 2 – Max. value to IEC 60228
- 3, 4, 5, 6, 9 – Approx. values
- 7 – Calculated in accordance to IEC publications 60287 and the following assumptions
 - Max. conductor temperature at continuous load 90°C
 - Frequency 50 Hz
 - Max. ambient temperature 20°C
 - Screens bonded at both ends and connected to earth
 - burrial depth of cables 1.0 m
 - Thermal resistivity of surroundings 1.0 K·m/W
 - at current acc. to 7
- 8

Constructional Data, Electrical Data

3GSERAA 6/10(12) kV

Constructional Data

1	2	3	4	5	6	7	8	9
Nominal cross sectional area of conductor	Conductor copper round stranded diameter over conductor	Insulation EPR wall thickness	Screen copper toes cross sectional area	Bedding wall thickness	Armour steel wires round galvanized diameter	Serving bitumen fib. material and lime wash wall thickness	Outer diameter of cable	Cable weight
(mm ²)	(mm)	(mm)	(mm ²)	(mm)	(mm)	(mm)	(mm)	(t/km)
35	7.0	3.4	3x4	2.0	3.15	3.5	56	5.4
50	8.2	3.4	3x4	2.0	3.15	3.5	59	5.9
70	9.9	3.4	3x5.4	2.0	4.0	3.5	64	7.9
95	11.5	3.4	3x5.4	2.0	4.0	3.5	68	9.1
120	13.0	3.4	3x5.4	2.0	4.0	3.5	71	10.2
150	14.5	3.4	3x6	2.0	4.0	3.5	74	11.4
185	16.1	3.4	3x6	2.5	5.0	4.0	86	15.0
240	18.6	3.4	3x6	2.5	5.0	4.0	87	16.7

3GSERAA 6/10(12) kV

Electrical Data

1	2	3	4	5	6	7	8	9
Nominal cross sectional area	Conductor resistance DC 20°C	Conductor resistance AC 90°C	Screen resistance 20°C	Capacitance	Inductance	Current rating	Losses	1s short circuit current after full load at 90°C conductor temperature
conductor (mm ²)	screen (mm ²)	(Ω/km)	(Ω/km)	(μF/km)	(mH/km)	(A)	(W/m)	conductor (kA)
35	3x4	0.524	0.67	1.83	0.27	0.37	166	56
50	3x4	0.387	0.49	1.83	0.30	0.35	197	59
70	3x5.4	0.268	0.34	1.15	0.34	0.33	242	62
95	3x5.4	0.193	0.25	1.15	0.38	0.32	289	64
120	3x5.4	0.153	0.20	1.15	0.42	0.31	328	66
150	3x6	0.124	0.16	1.05	0.45	0.30	367	68
185	3x6	0.0991	0.13	1.05	0.49	0.29	402	67
240	3x6	0.0754	0.10	1.05	0.55	0.28	469	73

3GSERAA 12/20(24) kV
Constructional Data

1	2	3	4	5	6	7	8	9
Nominal cross sectional area of conductor (mm ²)	Conductor copper round stranded diameter over conductor (mm)	Insulation EPR wall thickness (mm)	Screen copper tapes cross sectional area (mm ²)	Bedding wall thickness (mm)	Armour steel wires round galvanized diameter (mm)	Serving bitumen fib. material and lime wash wall thickness (mm)	Outer diameter of cable (mm)	Cable weight (t/km)
35	7.0	5.5	3x6	2	3.15	3.5	65	6.8
50	8.2	5.5	3x6	2	3.15	3.5	68	7.4
70	9.9	5.5	3x6	2	4.0	3.5	73	9.5
95	11.5	5.5	3x6	2	4.0	3.5	77	10.7
120	13.0	5.5	3x6	2	4.0	3.5	80	11.8
150	14.5	5.5	3x6	2	4.0	3.5	83	13.0
185	16.1	5.5	3x8	2	5.0	4.0	90	16.2
240	18.6	5.5	3x8	2	5.0	4.0	95	18.5

3GSERAA 12/20(24) kV
Electrical Data

1	2	3	4	5	6	7	8	9
Nominal cross sectional area conductor (mm ²) screen (mm ²)	Conductor resistance DC 20°C (Ω/km)	Conductor resistance AC 90°C (Ω/km)	Screen resistance 20°C (Ω/km)	Capacitance (µF/km)	Inductance (mH/km)	Current rating (A)	Losses (W/m)	1s short circuit current after full load at 90°C conductor temperature (kA) screen (kA)
35 3x6	0.524	0.67	1.05	0.19	0.41	166	57	5.0 3.3
50 3x6	0.387	0.49	1.05	0.21	0.39	197	59	7.1 3.3
70 3x6	0.268	0.34	1.05	0.24	0.37	241	62	10.0 3.3
95 3x6	0.193	0.25	1.05	0.26	0.35	288	65	13.6 3.3
120 3x6	0.153	0.20	1.05	0.29	0.34	327	67	17.1 3.3
150 3x6	0.124	0.16	1.05	0.31	0.33	365	69	21.4 3.3
185 3x8	0.0991	0.13	0.73	0.33	0.32	409	71	26.5 4.3
240 3x8	0.0754	0.098	0.73	0.37	0.31	470	74	34.3 4.3

3GSERAA 18/30(36) kV
Constructional Data

1	2	3	4	5	6	7	8	9
Nominal cross sectional area of conductor (mm ²)	Conductor copper round stranded diameter over conductor (mm)	Insulation EPR wall thickness (mm)	Screen copper tapes cross sectional area (mm ²)	Bedding wall thickness (mm)	Armour steel wires round galvanized diameter (mm)	Serving bitumen fib. material and lime wash wall thickness (mm)	Outer diameter of cable (mm)	Cable weight (t/km)
50	8.2	8.0	3x6	2	3.15	3.5	79	9.2
70	9.9	8.0	3x6	2	4.0	3.5	84	11.5
95	11.5	8.0	3x8	2	4.0	3.5	88	12.8
120	13.0	8.0	3x8	2	4.0	3.5	91	14.0
150	14.5	8.0	3x8	2	4.0	3.5	94	15.4
185	16.1	8.0	3x10	2	5.0	4.0	101	18.7
240	18.6	8.0	3x10	2	5.0	4.0	106	21.1

3GSERAA 18/30(36) kV
Electrical Data

1	2	3	4	5	6	7	8	9
Nominal cross sectional area conductor (mm ²) screen (mm ²)	Conductor resistance DC 20°C (Ω/km)	Conductor resistance AC 90°C (Ω/km)	Screen resistance 20°C (Ω/km)	Capacitance (µF/km)	Inductance (mH/km)	Current rating (A)	Losses (W/m)	1s short circuit current after full load at 90°C conductor temperature (kA) screen (kA)
50 3x6	0.387	0.49	1.05	0.17	0.43	196	59	7.1 3.3
70 3x6	0.268	0.34	1.05	0.18	0.41	241	62	10.0 3.3
95 3x8	0.193	0.25	0.73	0.20	0.39	287	65	13.6 4.3
120 3x8	0.153	0.20	0.73	0.22	0.37	325	67	17.1 4.3
150 3x8	0.124	0.16	0.73	0.23	0.36	364	69	21.4 4.3
185 3x10	0.0991	0.13	0.63	0.25	0.35	406	72	26.5 5.4
240 3x10	0.0754	0.098	0.63	0.28	0.33	467	75	34.3 5.4

Applications



Offshore production platform in Indonesia, with power supply through a submarine cable



34.5 kV shore substation submarine cable project Mindanao, Philippines

Landing a submarine cable at shore of an Australian Island



Laying of inter turbine cables for
Horns Rev offshore windpark, Denmark



Nexans welcomes your inquiries. For elaboration of a proposal most suitable for your individual requirements, detailed informations should be given to the following questions (as far as applicable):

1. Application

Attach plan of layout, if possible

2. Transmitted voltage

Rated system voltage (U_o/U)

Highest continuous voltage (U_m)

Operating frequency

3. Transmitted power

Rated transmitted power (kVA)

Short circuit current (kA)

Short circuit duration (s)

4. Type of operation

Public network (load cycling)

Continuous full load operation

Requirements for control/telecommunication circuits

5. Grounding conditions

6. Conditions of cable route

Length of cable route (route plan)

Water depth

Water flow conditions/tide

Thermal resistance of the soil

Laying depth

Soil temperature

Conditions of the cable route at the beginning and at the end

Cable laying in pipes or in the air

Ambient temperature

On-shore cable protection requirements

7. Transport and laying conditions

Required laying method (laying on bottom, water jet trenching)

Will laying be performed by customer or separate subcontractor

Are there limitations for handling sizes and weights

Are cable laying barges available

Load carrying capacity of the laying barge

Dimensions of the loading platform



Global experts in cables and cabling systems

Nexans Deutschland GmbH · Energy Networks
Kabelkamp 20 · 30179 Hannover
Tel.: +49 511 6 76-1 · Fax: +49 511 6 76 2444 · www.nexans.de