

Document : ABS1497/C
Date : 07/03/2024



#smartconnection

NOTICE / INSTRUCTIONS



OUTDROP 2+

Boîtier d'épissurage
Splicing box

www.aginode.net



Table des matières

Table of contents

1. DESCRIPTION	
OVERVIEW	4
1.1. PRÉSENTATION DU BOÎTIER	
<i>DEVICE OVERVIEW</i>	4
2. KITS FOURNIS	
KITS PROVIDED	11
2.1. KIT DE FIXATION MURALE	
<i>WALL MOUNTING KIT</i>	11
2.2. KITS DE PEIGNES	
<i>COMB KITS</i>	11
2.3. KIT DE COLLIERS DE FIXATION DE CÂBLES	
<i>PLASTIC TIES KIT</i>	12
3. KITS OPTIONNELS	
OPTIONAL KITS	12
4. PRÉPARATION DU BOÎTIER	
PREPARING THE DEVICE	13
4.1. OUVERTURE DU BOÎTIER	
<i>OPENING THE DEVICE</i>	13
4.2. DÉPOSE DU CAPOT	
<i>DISASSEMBLING THE COVER</i>	15
5. INSTALLATION DU BOÎTIER	
MOUNTING	16
5.1. CAS DE L'INSTALLATION MURALE	
<i>WALL MOUNTING</i>	16
5.2. CAS DE L'INSTALLATION DIRECTE SUR POTEAU	
<i>DIRECT POLE MOUNTING</i>	17
5.3. CAS DE L'INSTALLATION AVEC UN SUPPORT UNIVERSEL (OPTION)	
<i>UNIVERSAL SUPPORT MOUNTING (OPTION)</i>	18
5.4. PRÉPARATION ET MISE EN PLACE DES JOINTS D'ÉTANCHÉITÉ	
<i>PREPARING AND INSTALLING THE CABLE SEALS</i>	19
6. PRÉPARATION DES CASSETTES	
PREPARING THE SPLICING TRAYS	21
6.1. OUVERTURE FERMETURE DE L'ORGANISEUR CASSETTES	
<i>OPENING AND CLOSING THE ORGANIZER</i>	21
6.2. PRÉPARATION DES CASSETTES	
<i>PREPARING THE SPLICE TRAYS</i>	22
7. PRÉPARATION ET INSTALLATION DU CÂBLE PRINCIPAL	
PREPARING AND INSTALLING THE MAIN CABLE	23

7.1.	PRÉPARATION DU CÂBLE PRINCIPAL <i>MAIN CABLE PREPARATION</i>	23
7.2.	PRINCIPE DE RACCORDEMENT DU CÂBLE PRINCIPAL <i>CONNECTING THE MAIN CABLE - PRINCIPLES</i>	25
7.3.	LOVAGE DES SURLONGUEURS <i>COILING THE OVERLENGTHS</i>	26
8.	PRÉPARATION ET RACCORDEMENT DES CÂBLES SECONDAIRES <i>PREPARING AND INSTALLING THE SECONDARY CABLES</i>	28
8.1.	PRÉPARATION DU CÂBLE SECONDAIRE <i>PREPARATION OF THE SECONDARY CABLE</i>	28
8.2.	PRINCIPE DE RACCORDEMENT DU CÂBLE SECONDAIRE <i>CONNECTION OF THE SECONDARY CABLE</i>	28
9.	EPISSURAGE DES FIBRES <i>SPLICING</i>	31
10.	FERMETURE DU BOÎTIER <i>CLOSING THE DEVICE</i>	32
10.1.	FERMETURE DE L'ORGANISEUR <i>CLOSING THE ORGANISER</i>	32
10.2.	RÉINSTALLATION DU CAPOT <i>REASSEMBLING THE COVER</i>	33
10.3.	FERMETURE DU CAPOT <i>CLOSING THE COVER</i>	34
11.	INSTRUCTIONS DE FIN DE VIE <i>END LIFE INSTRUCTIONS</i>	35

1. DESCRIPTION OVERVIEW

1.1. Présentation du boîtier *Device overview*

Le boîtier OutDrop 2+ Epissurage est spécialement conçu pour permettre le déploiement, au fil de l'eau, des câbles de raccordement optique.

Destiné à un usage extérieur et à une application en façade ou sur poteau, le boîtier OutDrop 2+ Epissurage permet un câblage en piquage épi ou en piquage droit.

Le boîtier existe en plusieurs versions d'épissurage (jusqu'à 4 cassettes de 12 épissures).

The OutDrop 2+ Splicing device is specially designed for deploying optical fibre or copper subscriber cables on demand.

The OutDrop 2+ Splicing device can be fitted either on pole mountings or building facades and offers different cabling possibilities such as standard configuration, butt or straight mid-span configuration.

The device exists in patching version (up to 2 splice trays, 12 splices each), and in splicing version (up to 4 splice trays, 12 splices each).

	Désignation	Designation	Qté / Qty
①	Boîtier	Case	1
②	Capot	Cover	1
③	Serrure triangulaire (en option, montée sur le boîtier, clé non fournie)	Triangular key lock (optional, mounted on the device, key not supplied)	1
④	Etiquette  (en option, à coller)	Safety sticker (optional)	1
⑤	Butées de retenue pour cassettes d'épissurage	Splice tray hinges	1
⑥	Plateau organisateur (monté sur le boîtier)	Organizer (mounted on the device)	1
⑦	Volets (à monter)	Shutters (not mounted)	4
⑧	Joints d'étanchéité latéraux (selon version)	Lateral seals (depending on version)	2
⑨	Joint d'étanchéité long pour câble principal et câbles de distribution	Mixed use seal (for main cable and distribution cables)	1



OUTILS NÉCESSAIRES

- Clé triangulaire 8 mm
- Matériel de dénudage standard
- Mètre
- Matériel de découpe des joints
- Tournevis cruciforme

REQUIRED TOOLS

- 8 mm triangular key
- Standard stripping tools
- Measuring tape
- Standard seal cutting tools
- Cross-head screwdriver

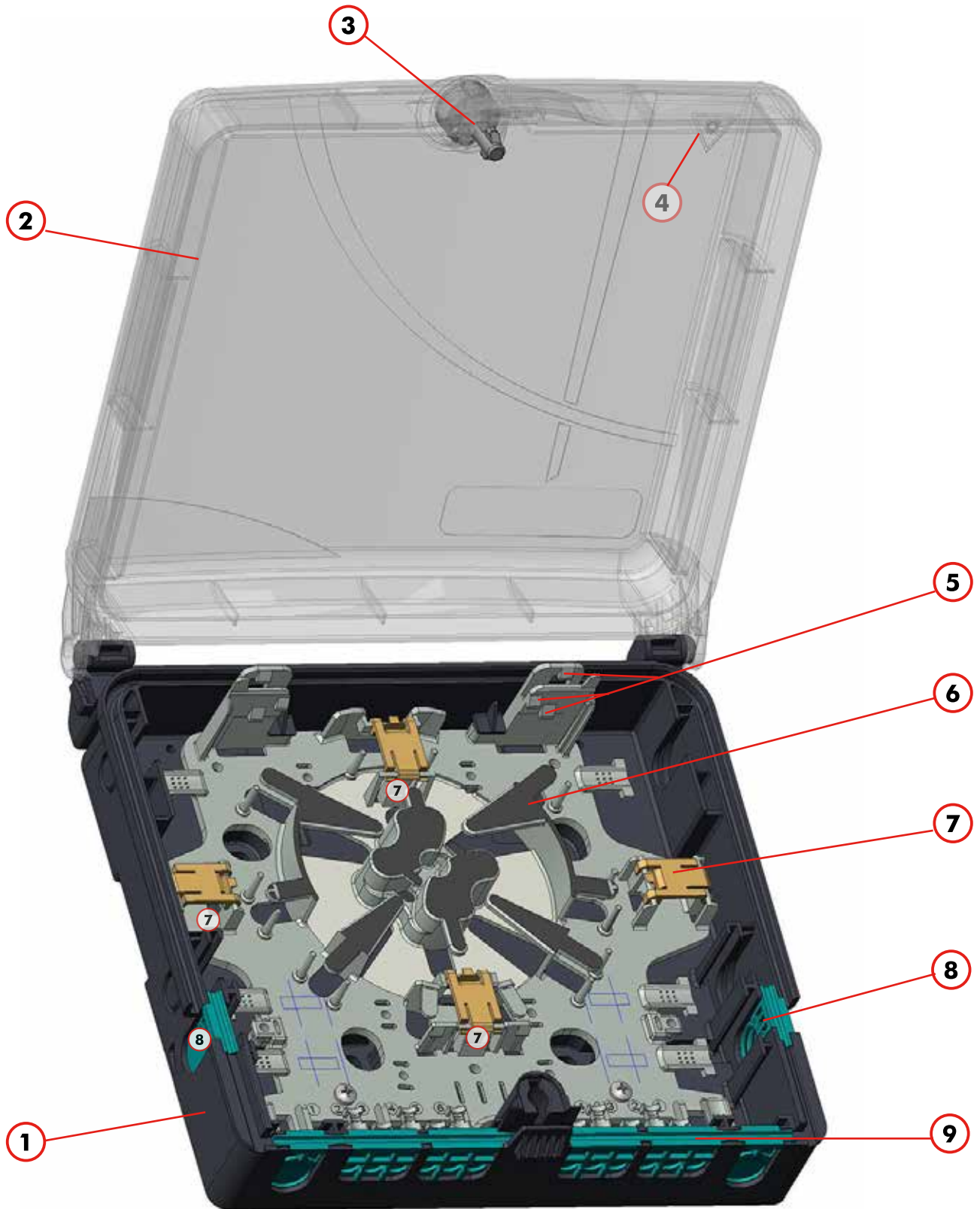

1.1.1. Boîtier épissure 48 fo Splicing version 48 fo

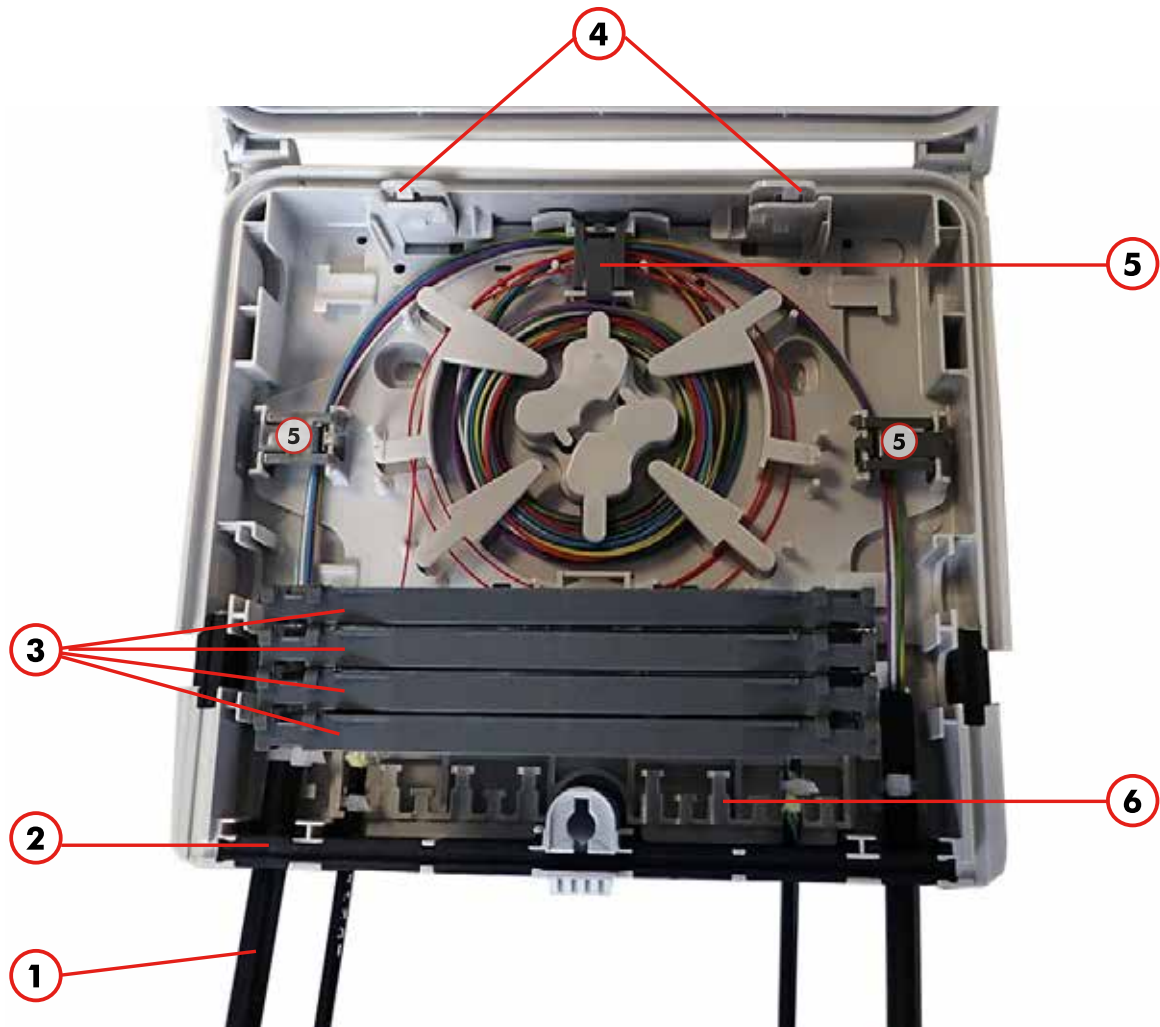

Fig. Version épissure 48 fo
Splicing version 48 fo

Désignation	Designation	Qté / Qty
① Câble principal	Main cable	1
② Joint d'étanchéité long pour câble principal et câbles de distribution	- Mixed use seal (for main cable and distribution cables)	1
③ Cassettes d'épissure	- Splice trays	4
④ Butées de retenue pour cassettes d'épissure	- Splice tray hinges	3
⑤ Anneaux de lovage à volets	- Coiling rings with shutters	2
⑥ Dispositif d'arrimage	- Clamping device	1

Zones de lovage et d'arrimage :

1. Une zone d'arrimage pour câbles de distribution.
2. Des zones d'arrimage pour câble principal (vertical ou horizontal) ②.
3. Un tambour de lovage interne permettant un lovage en S
4. Un zone de lovage des modules issus du câble principal.
5. Zone d'acheminement des modules du câble principal ou des câbles de distribution vers les cassettes.

Coiling and clamping zones:

1. A clamping area for distribution cables.
2. Clamping areas for the main cable (vertical or horizontal clamping) ②.
3. A internal coiling drum for pattern.
4. A coiling area for bundles shunted from the main cable.
5. Routing area for bundles shunted from the main cable or distribution cables towards splicing cassettes.

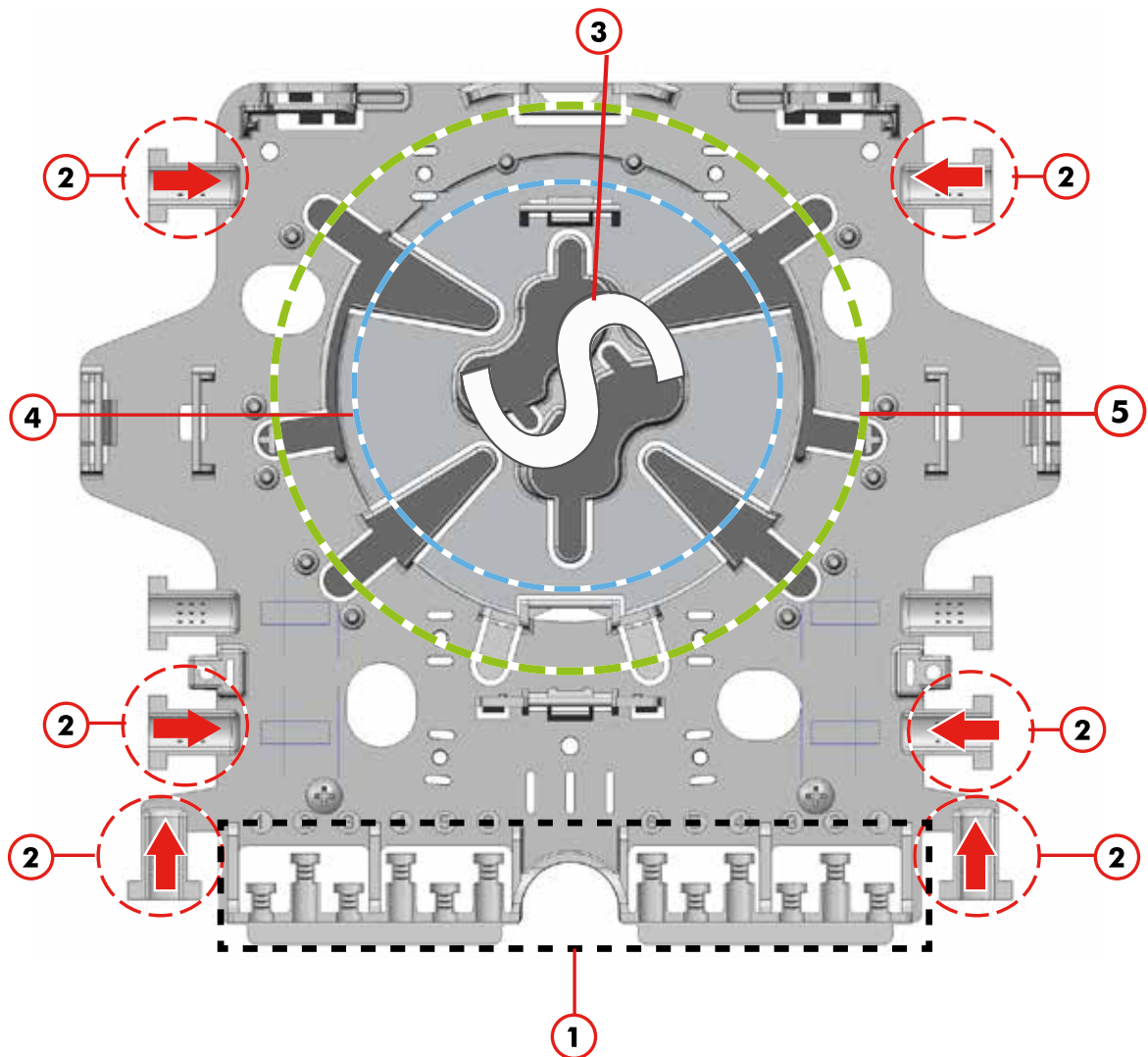

Fig. Zones de lovage et d'arrimage du dispositif OutDrop 2+ Epissurage
Coiling and clamping zones of the OutDrop 2+ Splicing device

1.1.2. Cassettes d'épissurage *Splicing trays*

Les cassettes d'épissurage livrées avec le boîtier OutDrop 2+ Epissurage permettent :

- la mise en place de supports d'épissure d'une longueur de 45 à 60 mm,
- le lovage des surlongueurs de fibre 250 µm.

Les cassettes d'épissurage se composent des éléments suivants :

- 1-** 1 support d'épissurage,
- 2-** 2 volets de maintien,
- 3-** 2 peignes en plastique,
- 4-** 1 zone de lovage,
- 5-** 1 couvercle de protection transparent.

The splicing trays of the OutDrop 2+ Splicing device allow:

- the installation of splice holders with a length 45 to 60 mm.
- the coiling of extra 250µm fibre lengths.

The splicing trays are made up of the following elements:

- 1-** 1 splice holder,
- 2-** 2 shutters,
- 3-** 2 plastic combs,
- 4-** 1 coiling area,
- 5-** 1 transparent plastic cover.

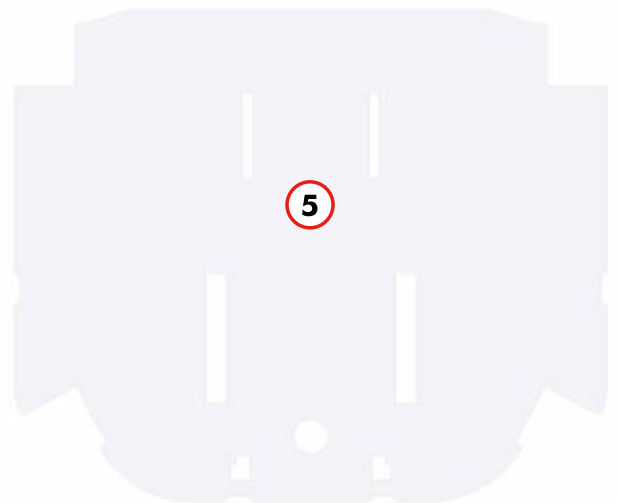
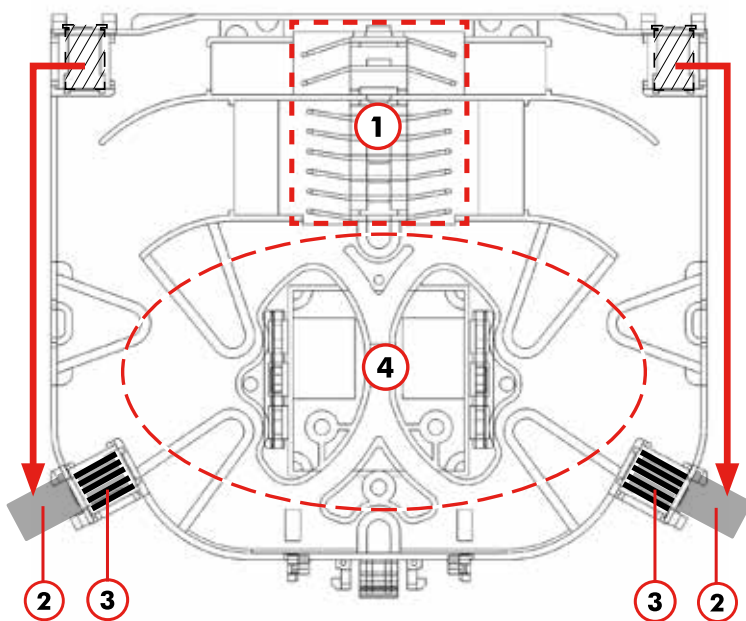

La capacité maximale du boîtier OutDrop 2+ Epissurage est de 48 épissures de fibres G652.

The OutDrop 2+ Splicing device has a maximal capacity of 48 splices of G657 optical fibres.

1.1.3. Caractéristiques techniques Technical characteristics

Matériaux	Extérieur : Boîtier et couvercle thermo-plastique Intérieur : Cassettes en polycarbonate	Materials	External: Thermoplastic case and cover Internal: Polycarbonate splice trays
Capacité	Max. 4 cassettes de 12 épissures chacune	Capacity	Up to 4 splice trays holding up to 12 splices.
Entrées de câbles	4 ports pour câble principal, Ø 14 mm maxi. 12 ports pour câbles abonnés, Ø 4 à 8 mm.	Cable ports	4 ports for main cable, Ø 14mm max. 12 cable ports for subscriber cables Ø 4 to 8mm.
Étanchéité	IP55	Tightness	IP55

- | | | | |
|--|-------------------|------------------------------------|-------------------|
| - Poids (à vide) : | 0,800 kg | - Weight (empty): | 0,800 kg |
| - Aspect : | RAL 7035 | - Finish: | RAL 7035 |
| - Dimensions (mm) - voir page suivante : | 245 x 237 x 78 mm | - Dimensions (mm) - see next page: | 245 x 237 x 78 mm |

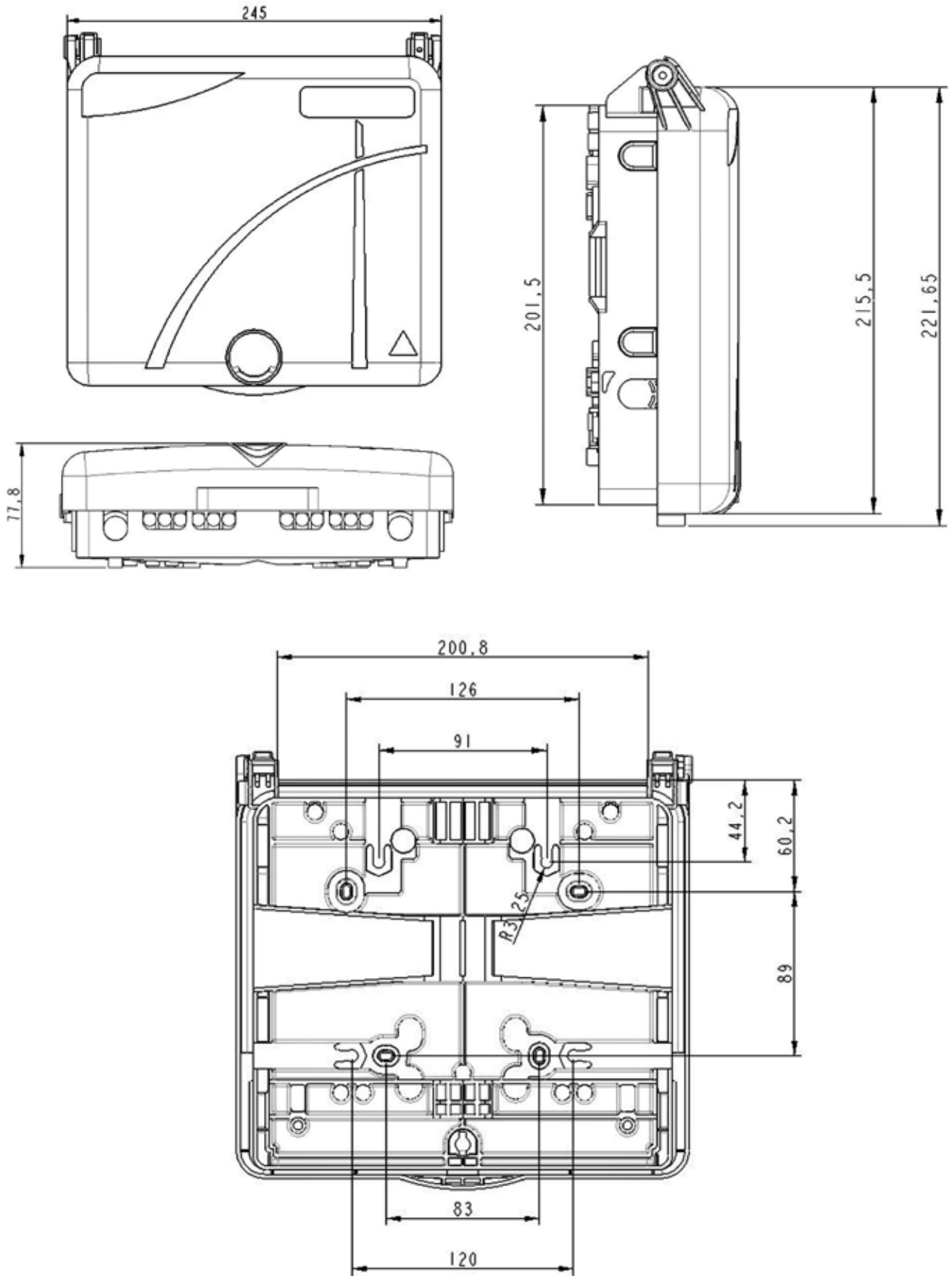

Fig. Boîtier OutDrop 2+ Epissurage : dimensions
Dimensions of the OutDrop 2+ Splicing device

2. KITS FOURNIS KITS PROVIDED

Le boîtier OutDrop 2+ Epissurage est livré avec les éléments suivants :

- 1 kit de fixation murale,
- 1 kit de peignes,
- 1 kit de colliers de fixation de câbles.

The OutDrop 2+ Splicing device includes the following elements:

- 1 wall mounting kit,
- 1 combs kit,
- 1 plastic ties kit.

2.1. Kit de fixation murale Wall mounting kit

Le kit de fixation murale est composé des éléments suivants :

The wall mounting kit contains the following elements:

Désignation	Designation	Qté / Qty
Vis de fixation Ø 6	- Fixation screws Ø 6	4
Chevilles de fixation Ø 8	- Wall anchors Ø 8	4
Rondelles	- Washers	4
Etiquette (en option)	- Laser safety tag (optional)	1



2.2. Kits de peignes Comb kits

2.2.1. Kit de peignes spécifiques micromodules Microbundle Comb kit

Le peigne dédié aux pigtails de Ø1,1mm est le peigne plastique 25 (Ø900 µm) avec outils d'aide à la mise en place des micro-modules.

The specific comb used for Ø1,1mm pigtails is the plastic comb 25 (Ø900 µm), with tool.

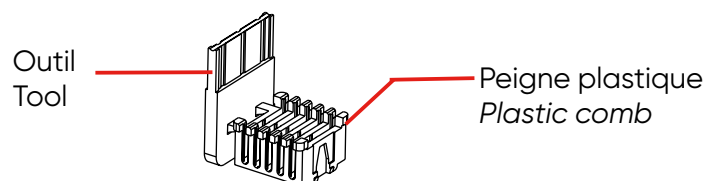

Fig. Peigne pour micromodule Ø900 µm et outil d'aide à la mise en place
Plastic comb for Ø900 µm microbundle and its tool

2.2.2. Grappe de peignes spécifiques loose tube *Loose tube Comb kit*

Le kit de peignes est composé des éléments suivants : *The comb kit contains the following elements:*

- 3 peignes en plastique n°1, Ø1,6 mm, - 3 plastic combs n°1, Ø1.6 mm,
- 3 peignes en plastique n°2, Ø2,4 mm, - 3 plastic combs n°2, Ø2.4 mm,
- 3 peignes en plastique n°3, Ø2,8 mm. - 3 plastic combs n°3, Ø2.8 mm.



Ø 1,6 mm



Ø 2,4 mm



Ø 2,8 mm

Fig. Peignes spécifiques loose tube
Loose tube combs

2.3. Kit de colliers de fixation de câbles *Plastic ties kit*

Le kit de colliers plastique est composé des éléments suivants :

The plastic ties kit contains the following elements:

- 4 colliers de fixation en plastique translucide grand modèle, utilisés pour la fixation du câble de principal. - 4 large translucent plastic ties, used to tie the principal cable.
- 12 colliers de fixation en plastique petit modèle, utilisés pour la fixation des câbles abonnés. - 12 small plastic ties; used to tie client cables.

3. KITS OPTIONNELS *OPTIONAL KITS*

2 kits d'arrimage sont disponibles en option :

2 clamping kits are available as an option:

- 1 kit de fixation du boîtier, comprenant un support universel, 2 écrous et 2 rondelles; - 1 mounting kit, containing a universal support mounting; 2 nuts and 2 washers.
- 1 kit de tés d'arrimage externe. **A** - 1 external clamping kit with T-square clamps.

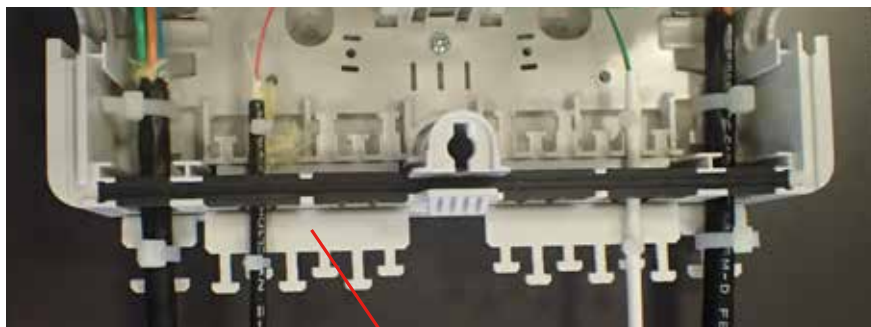

A

4. PRÉPARATION DU BOÎTIER PREPARING THE DEVICE

4.1. Ouverture du boîtier Opening the device



Pour les boîtiers ne disposant pas de serrure, passer directement à l'étape n°2.

If your device is not equipped with a lock, please proceed to step 2 directly.

1. Utiliser une clé triangulaire 8 mm (non fournie) pour faire pivoter le 1/4 tour dans le sens anti-horaire et déverrouiller le boîtier.
2. Faire pivoter le capot à 110° vers le haut.

1. Use a 8 mm triangular key (not included) to operate an anticlockwise rotation and unlock the device.
2. Rotate the cover 110° upwards to open the device.



Fig. Ouverture du boîtier OutDrop 2+ Epissurage
Opening the OutDrop 2+ Splicing device

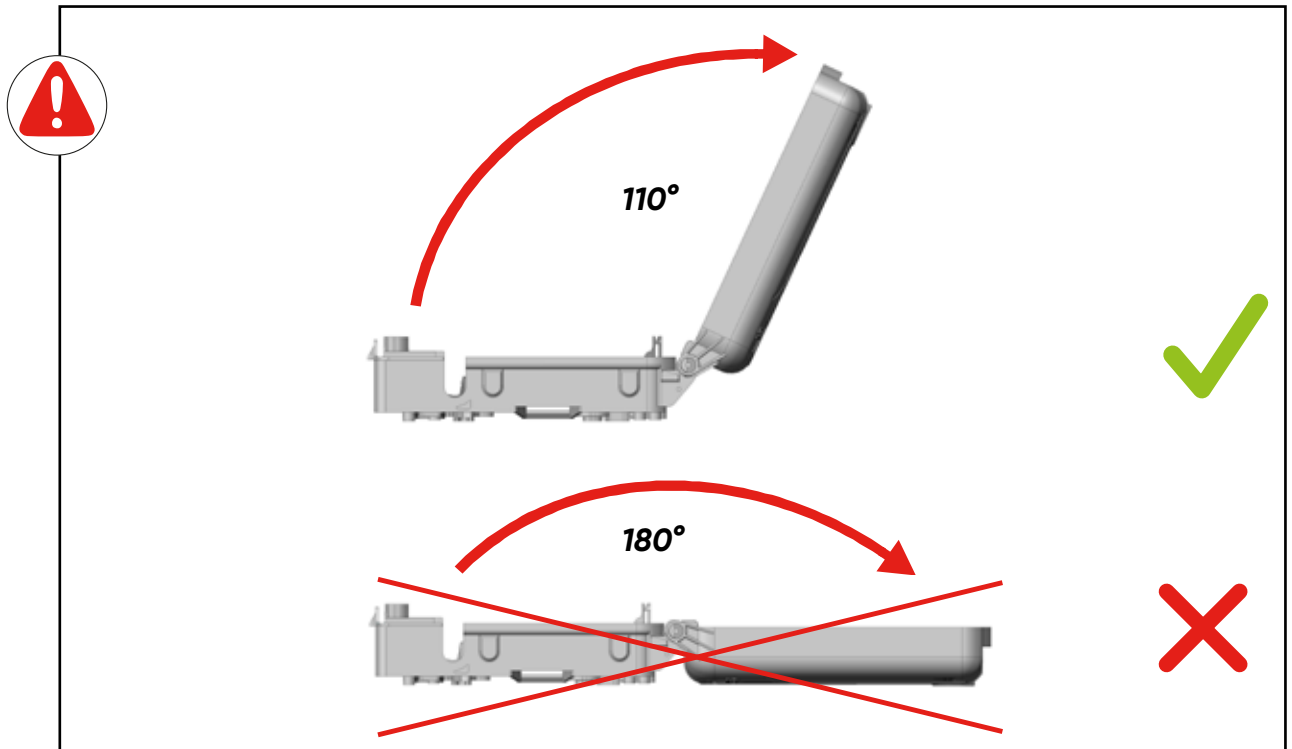
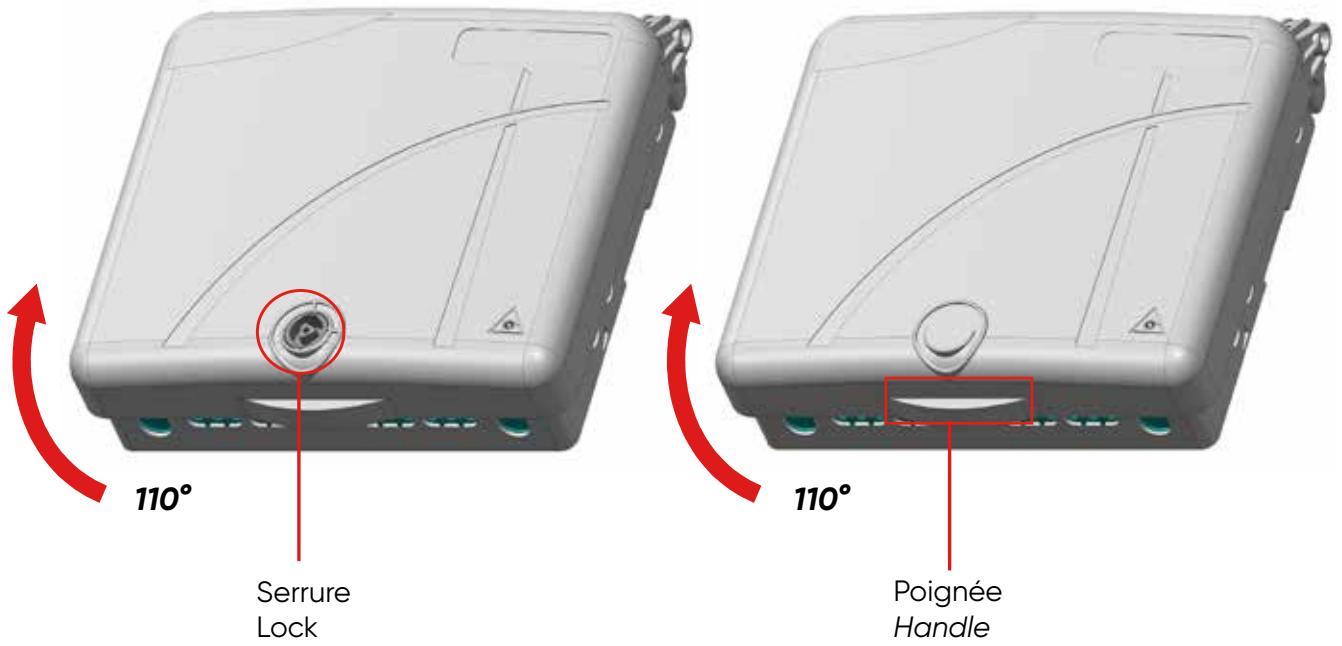

4.2. Dépose du capot *Disassembling the cover*



Le capot du dispositif est conçu pour rester ouvert lors des interventions à l'intérieur du boîtier. La dépose du capot est donc optionnelle.

The cover of the device is designed to remain open while operators proceed to splicing operations. The cover disassembly is optional.

1. Incliner le capot à 35° environ.
2. Pousser le capot vers la gauche, jusqu'à ce que son côté gauche se désolidarise du dispositif.
3. Conserver la même inclinaison et faire coulisser le capot vers la droite pour le désolidariser totalement.

1. Perform a 35° rotation on the cover.
2. Push the cover towards the left, until the left leg comes off the device.
3. Keeping the 35° angle, gently slide the cover to the right to remove it totally.

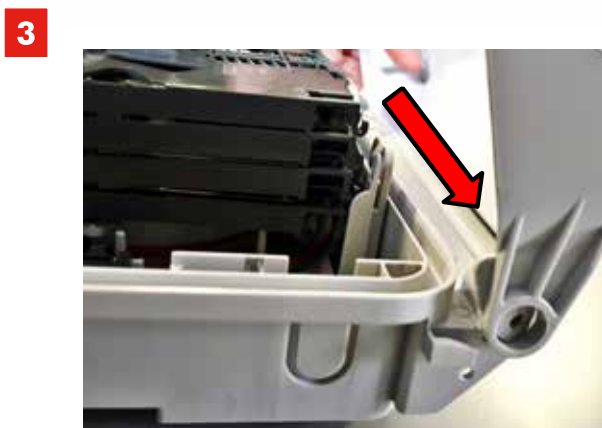
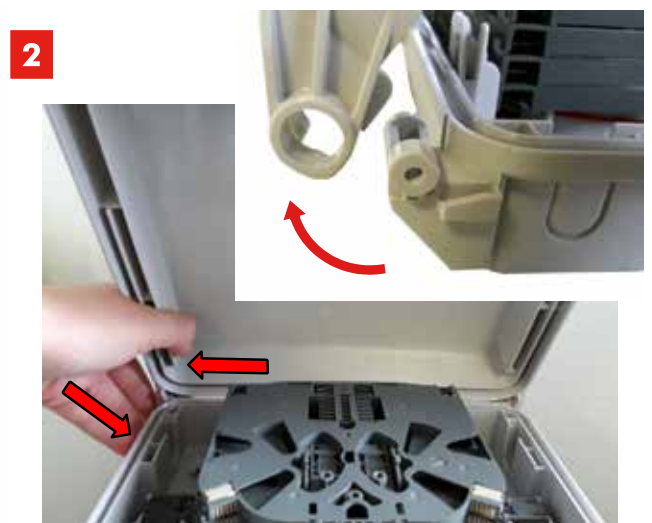
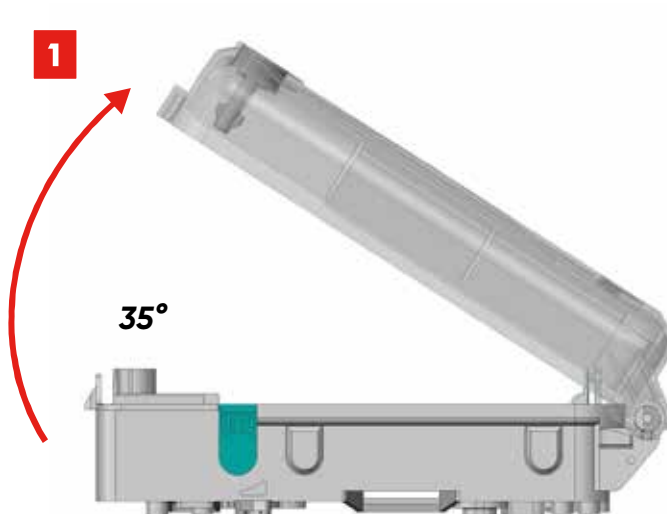

5. INSTALLATION DU BOÎTIER MOUNTING

5.1. Cas de l'installation murale Wall mounting

- | | |
|--|---|
| <ol style="list-style-type: none"> 1. Localiser les 4 opercules de fixation sur le dispositif. 2. Choisir 2 gabarits de perçage et désoperculer à l'aide d'un tournevis. 3. Utiliser les chevilles et les vis de fixation pour procéder à la fixation murale du dispositif. | <ol style="list-style-type: none"> 1. Identify the 4 cover plates on the device. 2. Choose 2 of them and pierce them using a screwdriver. 3. Use the wall anchors and the fixation screws to mount the device on the wall. |
|--|---|



Si le boîtier est déjà câblé, veiller à ne pas endommager les fibres.

Please be careful not to break the fibres if the device is already equipped with fiber optic.

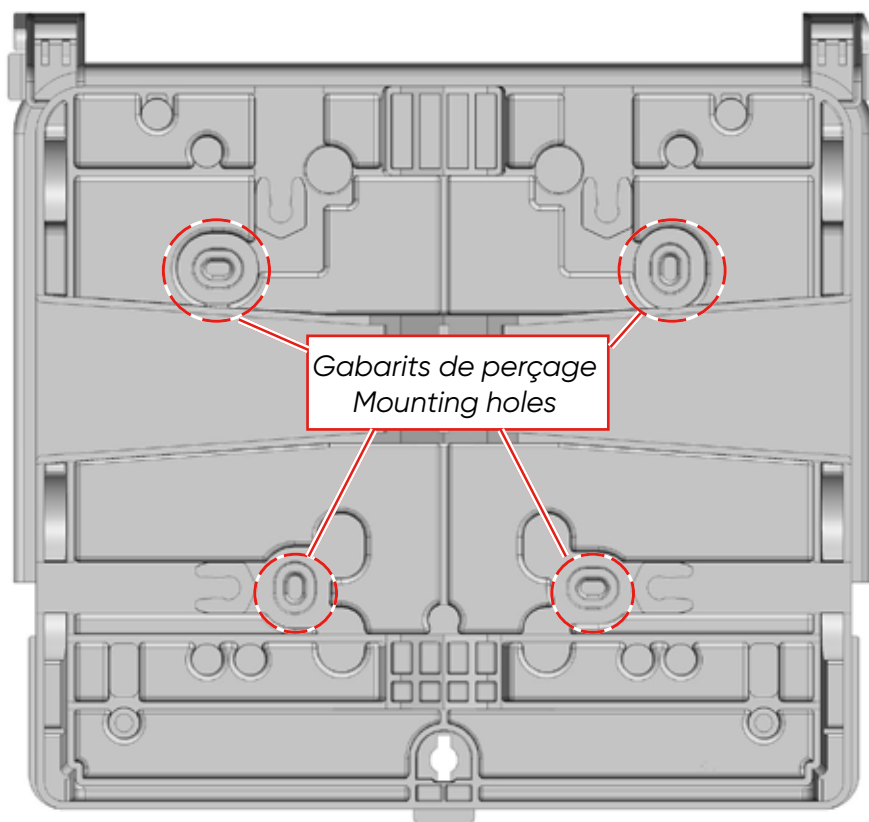

Fig. Gabarits de perçage - vue du dessous du boîtier
Mounting holes -bottom view



Choisir et utiliser 2 gabarits pour le perçage et l'installation des chevilles.

Choose and use 2 mounting holes to fit the anchors.

5.2. Cas de l'installation directe sur poteau *Direct pole mounting*

- | | |
|---|---|
| <ol style="list-style-type: none"> 1. Localiser les fentes au dos du boîtier OutDrop 2+ Epissurage. 2. Insérer un collier de fixation (feuillard inox) dans les fentes. | <ol style="list-style-type: none"> 1. <i>Identify the slots at the rear of the OutDrop 2+ Splicing.</i> 2. <i>Insert the mounting strap (stainless steel metal strip) in the slots.</i> |
|---|---|



La largeur du collier (feuillard inox) ne doit pas dépasser 25 mm.

The width of the mounting strap (stainless steel metal strip) must not exceed 25mm.

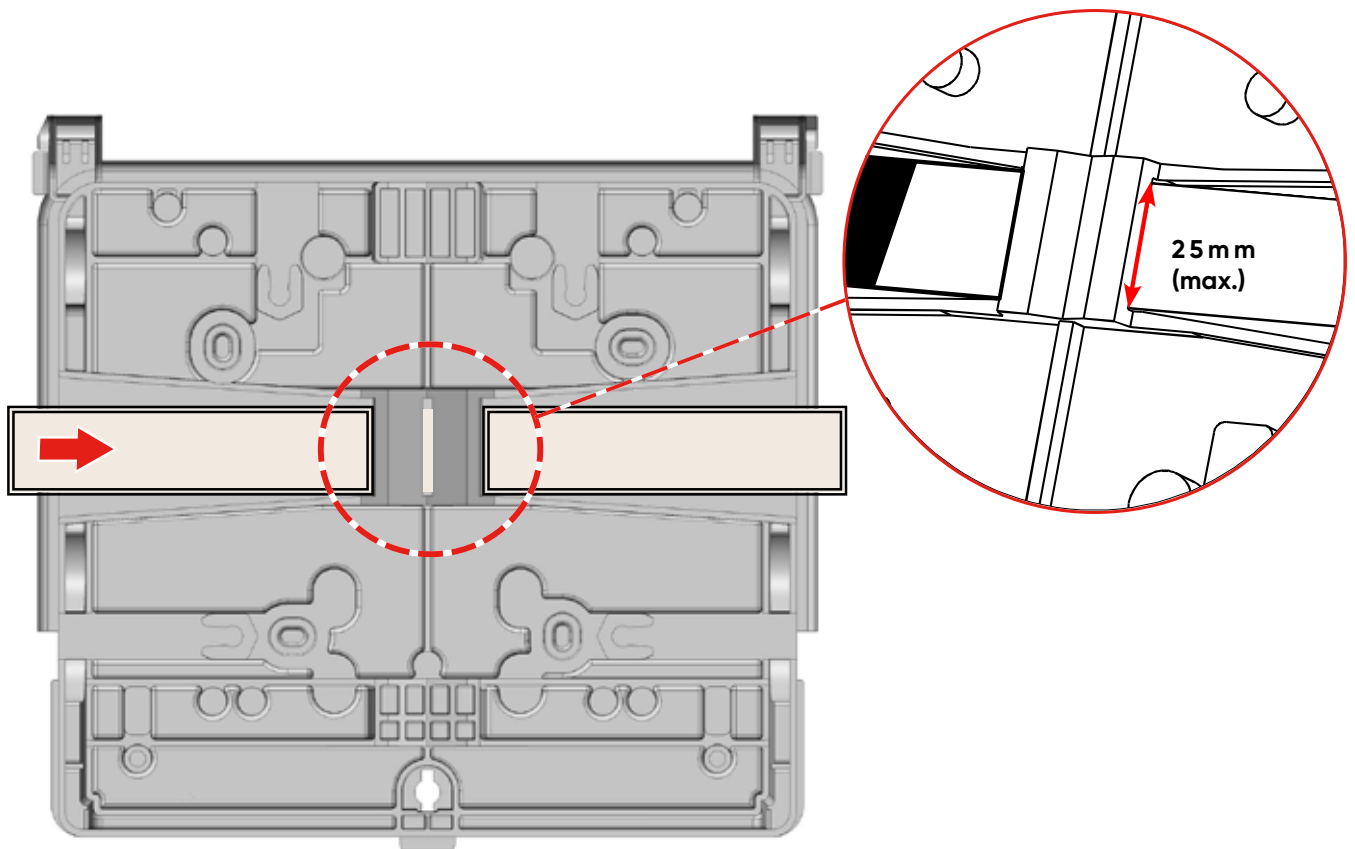

Fig. Installation du collier de fixation
Installing the mounting strap

5.3. Cas de l'installation avec un support universel (option) Universal support mounting (option)

- | | |
|--|---|
| <ol style="list-style-type: none"> 1. Sélectionner la position de fixation du/ des support(s) universel(s) (A et/ou B). 2. Insérer les vis dans le logement prévu à cet effet. | <ol style="list-style-type: none"> 1. Select the position of the universal support(s) (A and/or B). 2. Insert the screws in the dedicated slot. |
|--|---|



- | | |
|--|--|
| <ol style="list-style-type: none"> 3. Fixer le support universel à l'aide des deux écrous et rondelles prévus à cet effet. 4. Insérer un collier de fixation dans les fentes du support universel et fixer l'ensemble au poteau. | <ol style="list-style-type: none"> 3. Fix the universal support using the two dedicated nuts and washers. 4. Insert a mounting strap into the slots of the universal support and fix the device on the pole. |
|--|--|



La largeur du collier (feuillard inox) ne doit pas dépasser 19 mm.

The width of the collar (stainless steel metal strip) must not exceed 19mm.

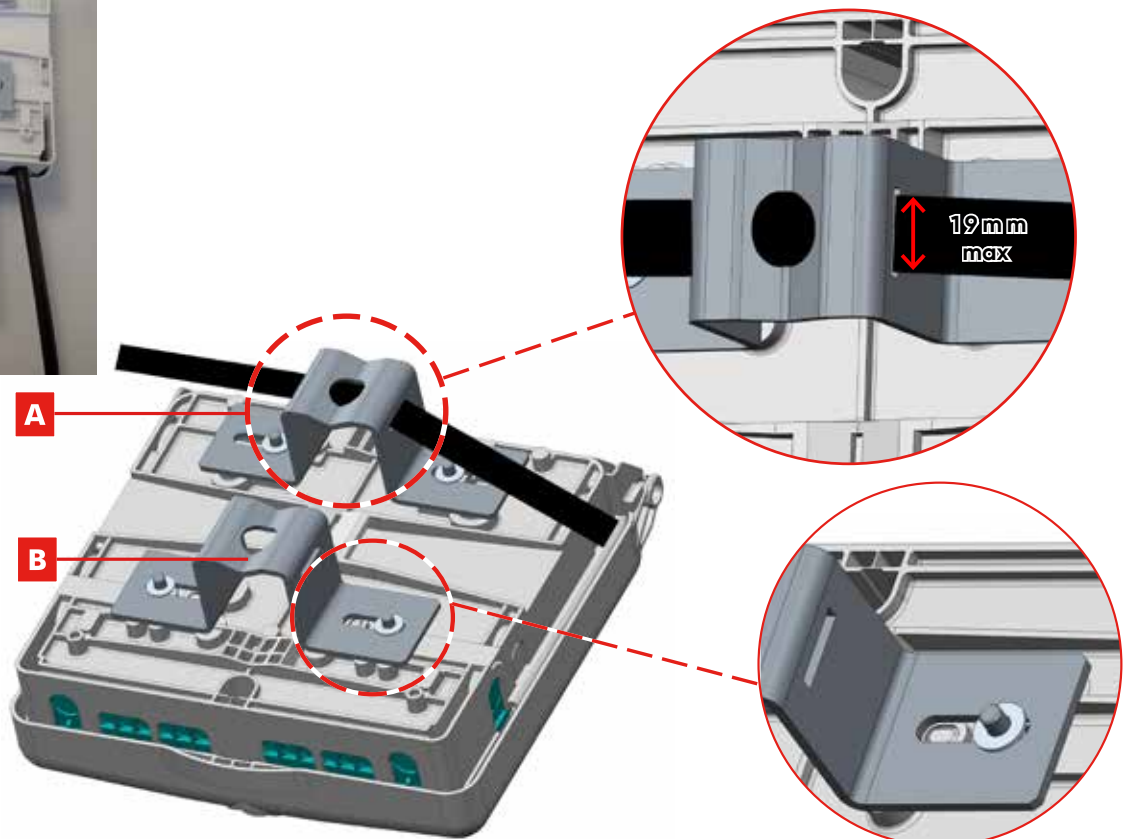

5.4. Préparation et mise en place des joints d'étanchéité Preparing and installing the cable seals

5.4.1. Joint d'étanchéité principal Main cable seal



Afin de préserver l'étanchéité du boîtier, veiller à découper uniquement les entrées nécessaires et à bien repositionner le joint principal après l'opération.

In order to preserve the sealing control of the device, cut out the necessary cable entries only. Also make sure the main cable seal is properly installed after the intervention.

Le joint d'étanchéité principal est composé des zones suivantes :

- 2 passages pour câbles principaux **A**.
- 4x3 passages pour câbles secondaires **B**.

The main cable seal is made up of the following areas:

- 2 main cable entries **A**.
- 4x3 secondary cable entries **B**.



Ces passages doivent être découpés selon le nombre de câbles utilisés uniquement.

Cable entries must be specifically cut out according to the number of cables used.

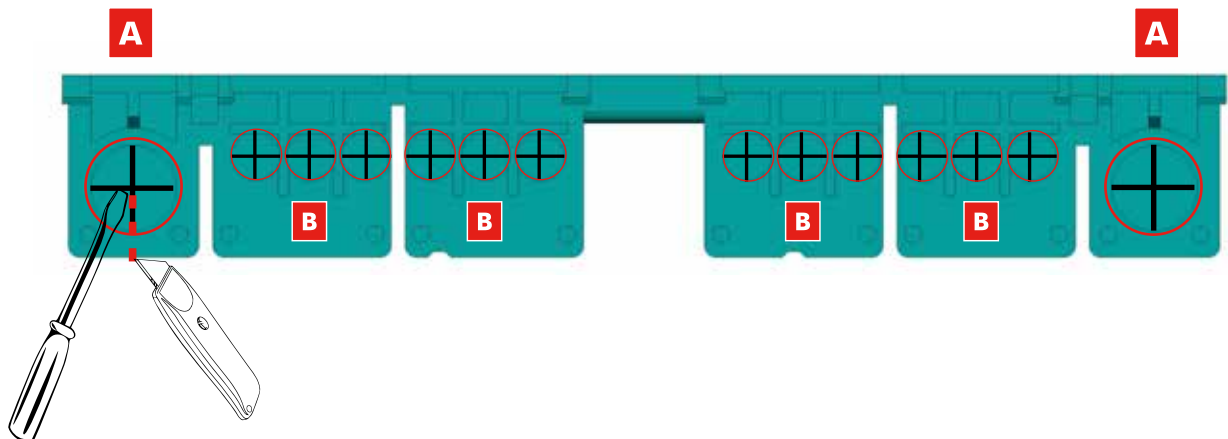

1. A l'aide d'un tournevis ou d'un outil pointu, percer les 2 passages en forme de croix.
2. A l'aide d'un cutter, pratiquer une incision verticale au niveau des 2 passages de câbles principaux **A** comme indiqué sur le schéma.

1. Use a screwdriver or a sharp tool to perform a x-shaped hole and allow cable entries.
2. Perform a vertical incision as depicted above in **A** using a box cutter.

5.4.2. Joints d'étanchéité latéraux (option) Lateral seals (optional)



Afin d'éviter tout problème d'étanchéité, il est recommandé de contrôler la propreté des joints, et de ne procéder à leur découpe qu'en cas d'utilisation effective.

To avoid any sealing control issues, please control the cleanliness of the seals and cut them only if intending to use them.

- | | |
|---|---|
| <ol style="list-style-type: none"> 1. Découper les entrées de câble en forme de croix sur les 2 joints latéraux. 2. Insérer les 2 joints latéraux dans les orifices dédiés, en respectant le sens d'introduction (rainures alignées). | <ol style="list-style-type: none"> 1. Cut the 2 lateral seals in a cross shape. 2. Insert the 2 lateral seals in the dedicated housings. Make sure they are installed properly (grooves aligned). |
|---|---|



Fig. Mise en place des joints d'étanchéité
Installing the cable seals

6. PRÉPARATION DES CASSETTES PREPARING THE SPLICING TRAYS

6.1. Ouverture fermeture de l'organiseur cassettes *Opening and closing the organizer*

- | | |
|---|---|
| <ol style="list-style-type: none"> 1. Pour ouvrir l'organiseur, ramener délicatement les cassettes vers vous pour les décrocher de leurs butées de retenue. 2. Pour fermer, pousser délicatement les cassettes vers l'organiseur et les encliqueter sur leur support de fixation. | <ol style="list-style-type: none"> 1. <i>To open the organizer, gently pull the splice trays from their hinge.</i> 2. <i>To close the organizer, gently push the splice trays and clip them on their hinge.</i> |
|---|---|



Afin de ne pas endommager les cassettes, veillez à bien décrocher l'ensemble des cassettes de leurs butées de retenue en même temps.

In order not to damage the splice trays, please make sure unclipping them from their hinge all at once.

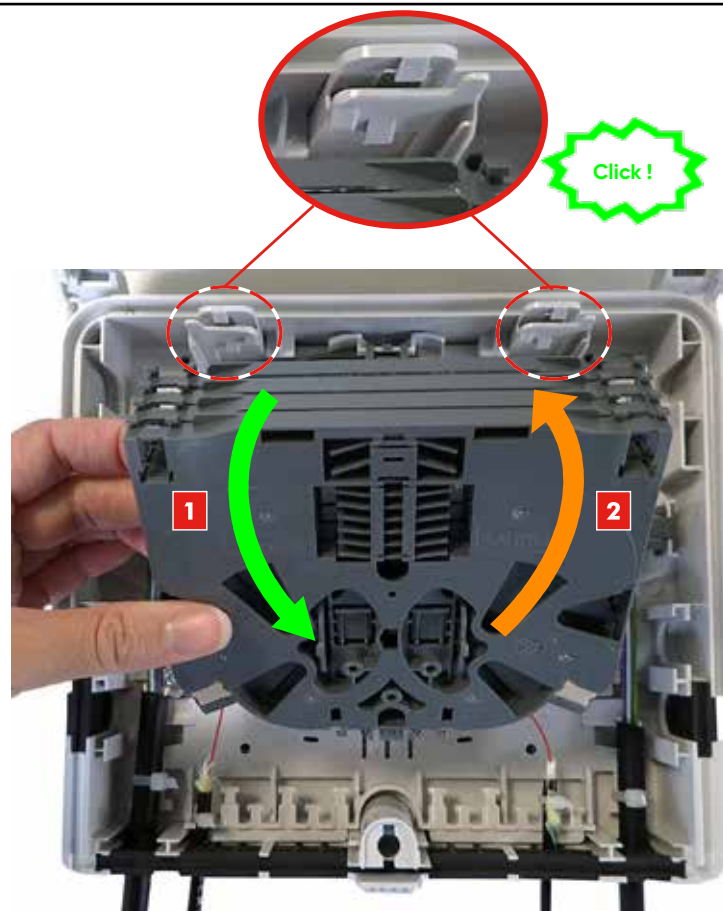

Fig. Ouverture et fermeture de l'organiseur
Opening and closing the organizer



Si l'intervention vise uniquement à raccorder un nouvel abonné (raccordement réseau déjà effectué), se reporter directement à la page 31.

If the intervention solely aims at connecting a new client (network connexion already set up), please refer to page 31 directly.

6.2. Préparation des cassettes *Preparing the splice trays*

- | | |
|---|--|
| <ol style="list-style-type: none"> 1. Détacher le couvercle de protection transparent de chaque cassette d'épissurage. 2. Détacher les volets des cassettes et les clipser de chaque côté. 3. Détacher les outils d'aide à la mise en place des peignes en plastique fournis dans le kit et les conserver. 4. Mettre en place 2 peignes (selon le type de câble utilisé) sur chaque cassette. | <ol style="list-style-type: none"> 1. Remove the protection cover from each splicing tray. 2. Detach the shutters from the splice trays and clip them on each side. 3. Detach the plastic tools provided in the combs kit and keep them for further use. 4. Place 4 combs (according to the cable type) on each splicing tray. |
|---|--|

1

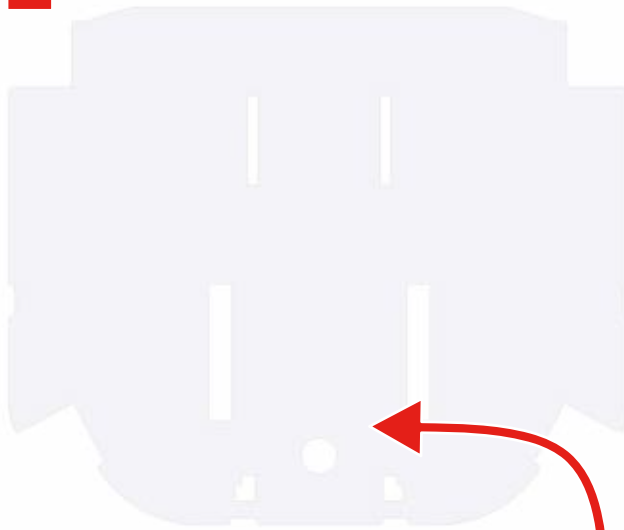

2

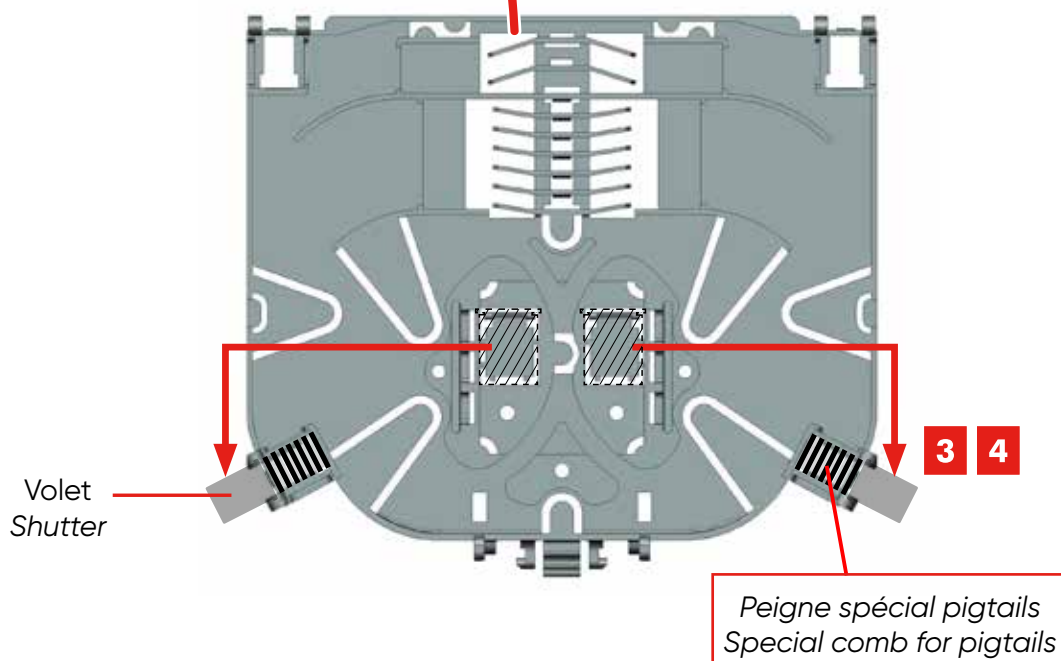
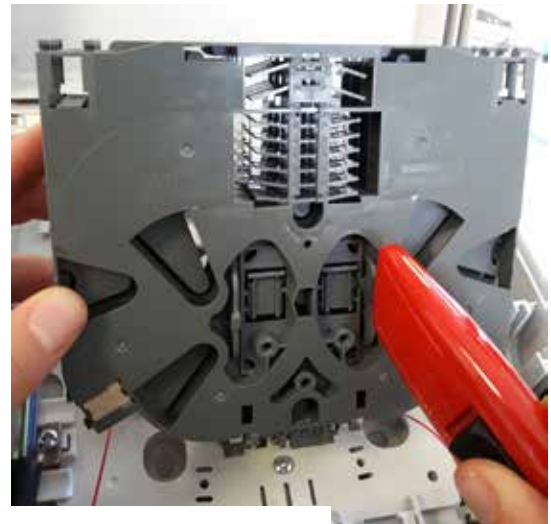

7. PRÉPARATION ET INSTALLATION DU CÂBLE PRINCIPAL PREPARING AND INSTALLING THE MAIN CABLE

7.1. Préparation du câble principal Main cable preparation



Si le câble nécessite d'être lové sur le tambour interne, réaliser une fenêtre supérieure à 1600 mm.

If the cable needs to be coiled around the drum, leave an opening of more than 1600 mm.

1. A l'aide d'un outil de dénudage, retirer la gaine du câble pour réaliser une fenêtre de **1600 mm**.
1. Use the dedicated tool to strip the sheath and leave an opening of **1600 mm**.

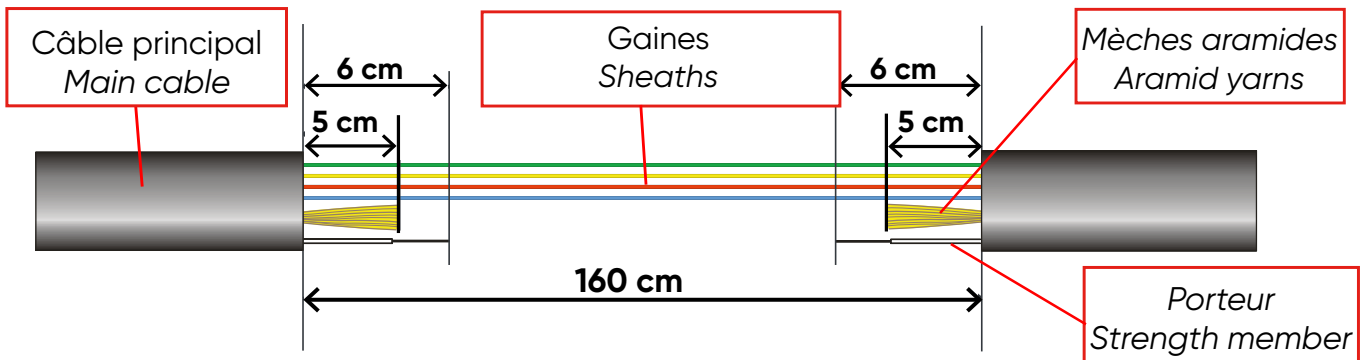

2. Sortir du toron le loose tube à dériver, et le couper à son extrémité.
2. Extract relevant loose tube from the bundle, and cut its end.

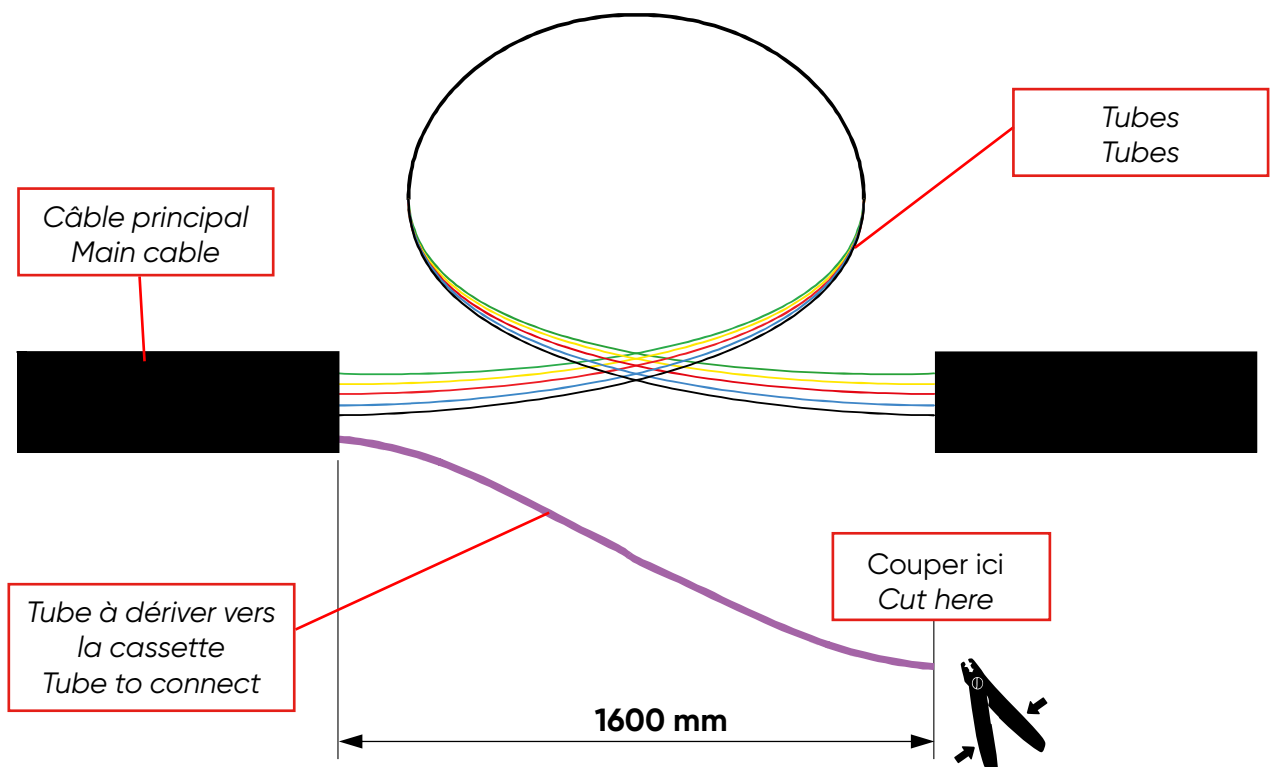

3. Dénuder le tube sur 1100 mm en laissant 500 mm en sortie de câble.
3. Strip the tube to leave 1100 mm of bare fiber and 500 mm of cable.

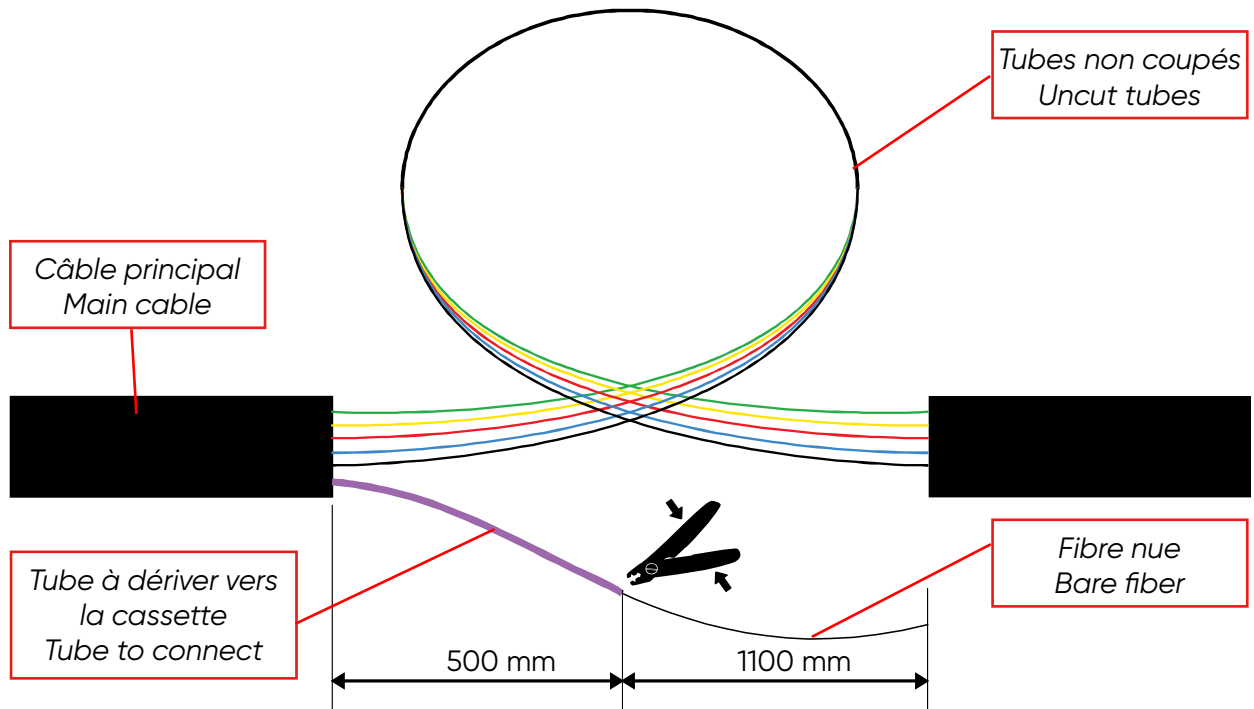

 **Selon l'environnement de l'installation, l'arrimage des aramides et des porteurs peut être le meilleur moyen d'éviter les phénomènes de pistonage.**

Depending on the installation environment, clamping the aramid yarns and strength members will be the best way to avoid cable piston effect.

7.2. Principe de raccordement du câble principal *Connecting the main cable - principles*

7.2.1. Mise en place des porteurs dans l'étrier *Installing the strength members in the clamp assembly*

- | | |
|--|--|
| <ol style="list-style-type: none"> 1. Insérer le câble principal à travers les passages prévus à cet effet (A). 2. Al'aide d'un tournevis cruciforme, déposer la vis de fixation de l'étrier et placer les 2 porteurs du câble principal sous l'étrier. | <ol style="list-style-type: none"> 1. <i>Insert the main cable in the dedicated cable entries (A)</i> 2. <i>Remove the screw from the clamp assembly using a cross-head screwdriver, and place the 2 strength members under the clamp assembly.</i> |
|--|--|

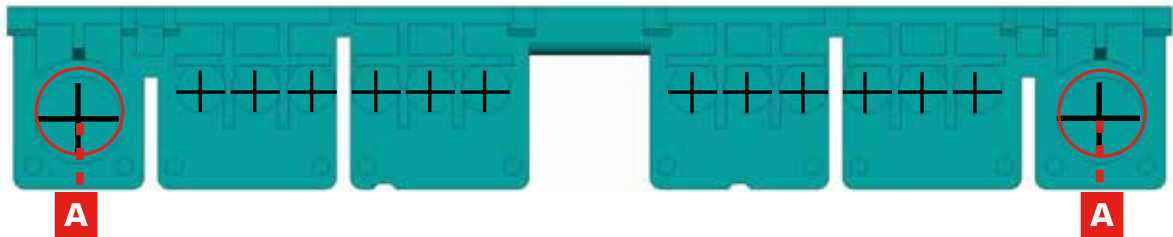

Attention à ne pas pincer les tubes.

Be careful to not damage the tubes .

- | | |
|--|--|
| <ol style="list-style-type: none"> 1. Repositionner la vis sur l'étrier et la fixer à l'aide du tournevis. 2. Renouveler l'opération de l'autre côté du boîtier. 3. Fixer le câble sur les arrimages de part et d'autre du boîtier à l'aide de colliers plastiques. | <ol style="list-style-type: none"> 1. <i>Re-install the screw and tighten it using the screwdriver.</i> 2. <i>Repeat the procedure on the other side of the device.</i> 3. <i>Clamp the cable on the clamps located on each side of the device using plastic ties..</i> |
|--|--|

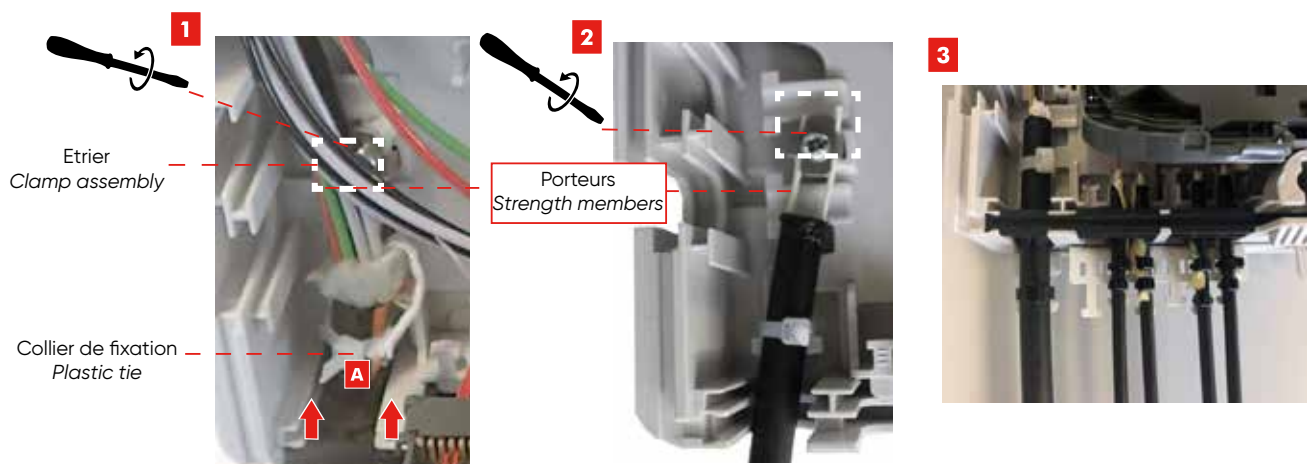

Des colliers métalliques peuvent être utilisés pour certains câbles aériens avec une épaisseur de gaine de 1,5 mm minimum. *Metallic collars can be used for some aerial cables with a sheath thickness of minimum 1.5mm.*

7.3. Lovage des surlongueurs *Coiling the overlengths*

- | | |
|---|---|
| <ol style="list-style-type: none"> 1. Faire pivoter les cassettes pour accéder aux zones de lovage. 2. Lover les surlongueurs du câble principal sous les doigts de lovage situés à l'intérieur du tambour de lovage en passant par l'ensemble des volets. 3. Arrimer les tubes dénudés dans les peignes des cassettes | <ol style="list-style-type: none"> 1. Rotate the splicing trays to access the coiling areas. 2. Coil overlengths of the main cable under the coiling legs located inside the coiling drum. Make sure cables are routed under all the shutters. 3. Clamp the strip tubes on the combs of the cassettes. |
|---|---|

	<p>Lors du lovage des surlongueurs, veiller à placer le câble autour du tambour intérieur, comme illustré.</p>	<p>When coiling the main overlengths, please make sure to do so around the inner coiling drum, as depicted.</p>
---	--	---

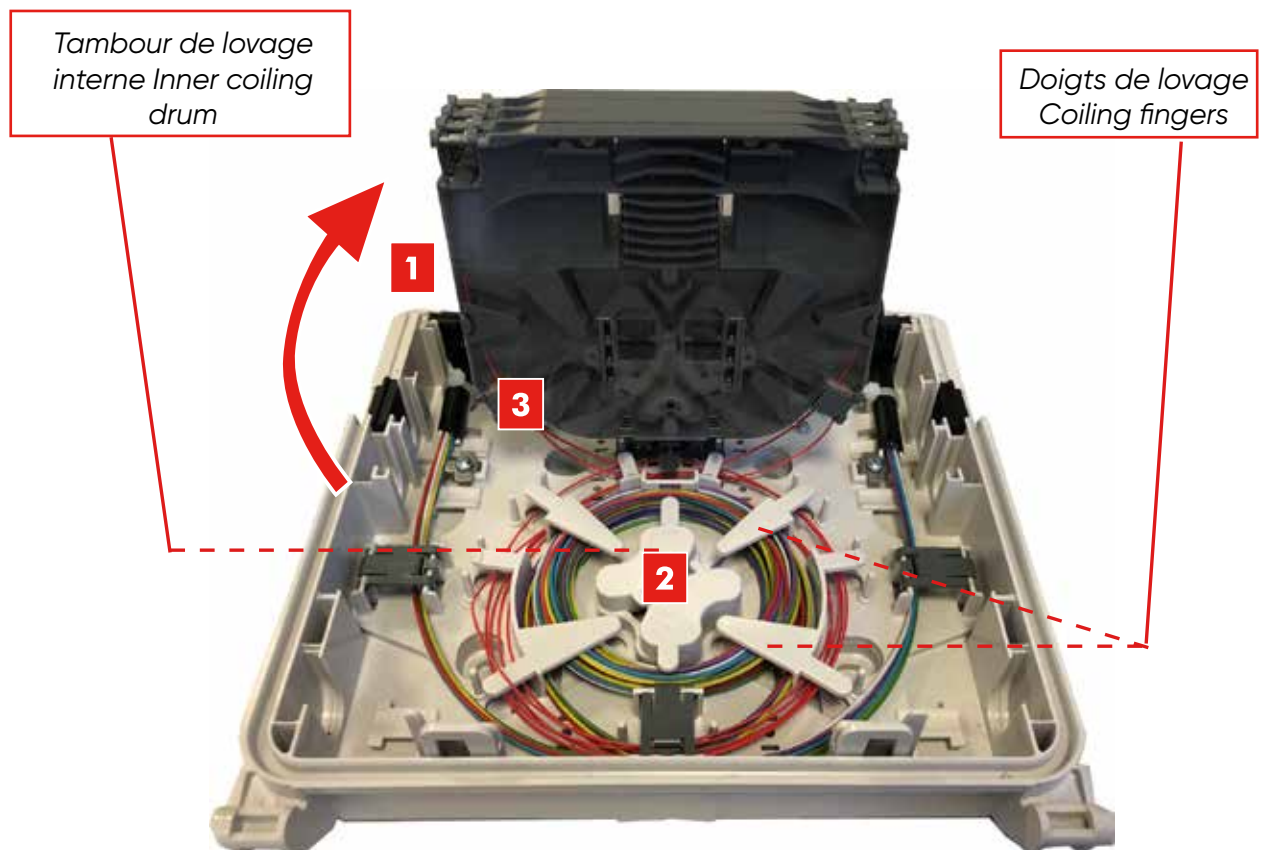



Fig. Lovage des micromodules - version microbundle
Coiling the microbundles - microbundle cable configuration

7.3.1. Version loosetube *Loosetube cable configuration*

- | | |
|---|---|
| <ol style="list-style-type: none"> 1. Faire pivoter les cassettes pour accéder aux zones de lovage. 2. Lever les surlongueurs du câble principal sous les anneaux de lovage situés à l'extérieur du tambour de lovage en passant par l'ensemble des anneaux à volets. | <ol style="list-style-type: none"> 1. Rotate the splicing trays to access the coiling areas. 2. Coil overlengths of the main cable under the coiling legs located outside the coiling drum. Make sure cables are routed under all the shutters. |
|---|---|

	<p>Lors du lovage des surlongueurs, veiller à placer le câble dans les anneaux de lovage, comme illustré.</p>	<p>When coiling the main overlengths, please make sure to do so around the coiling rings, as depicted.</p>
---	---	--

Tambour de lovage interne
Inner coiling drum

Anneaux de lovage
Coiling rings

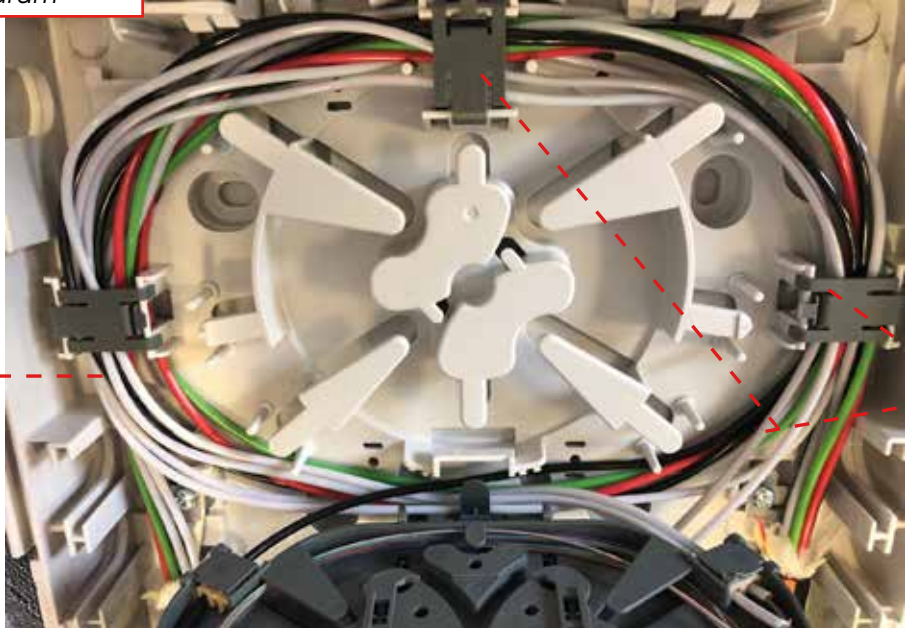

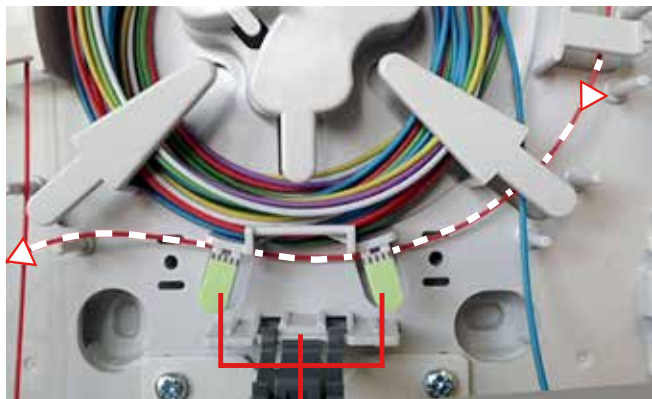

Fig. Lovage des micromodules - version loosetube
Coiling the microbundles - Loosetube cable configuration

	<p>Veiller à fermer l'ensemble des volets pour sécuriser les torons. <i>Please make sure the bundles are secured properly by closing all shutters.</i></p>
---	--



Guide-câble avec pattes de guidage sécables - version loosetube
Cable guide with breakable legs - version loosetube

8. PRÉPARATION ET RACCORDEMENT DES CÂBLES SECONDAIRES PREPARING AND INSTALLING THE SECONDARY CABLES

8.1. Préparation du câble secondaire Preparation of the secondary cable.



Si le câble nécessite d'être lové sur le tambour extérieur, dénuder la sur une longueur de 1600 mm.

If the cable needs to be coiled around the drum, leave an opening of more than 1600 mm.

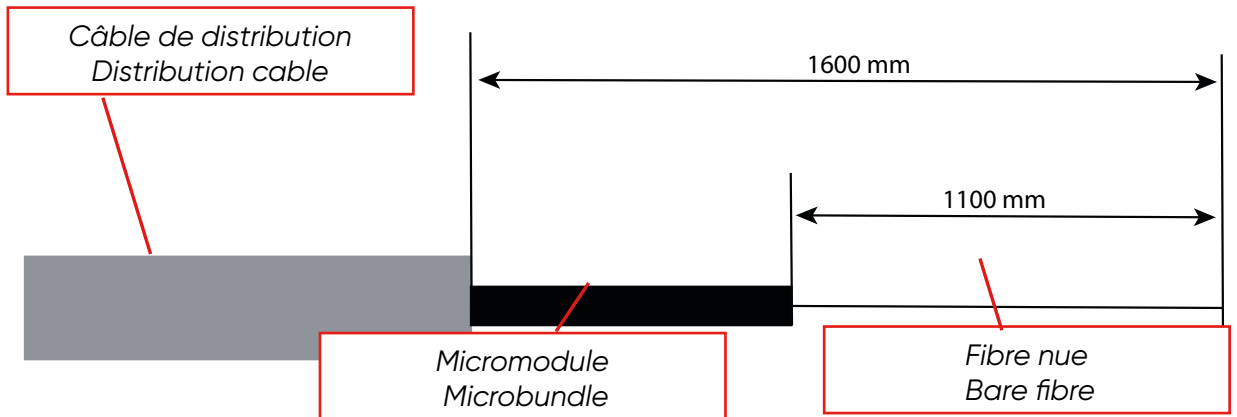

8.2. Principe de raccordement du câble secondaire Connection of the secondary cable

- | | |
|---|--|
| <ol style="list-style-type: none"> 1. Procéder au découpage des joints nécessaires comme indiqué. 2. Faire passer les câbles de distribution par les entrées de câbles. 3. Arrimer les câbles à l'aide de colliers plastique avec les mèches aramides. | <ol style="list-style-type: none"> 1. Cut the necessary seals as depicted. 2. Route the distribution cables through the cable entries. 3. Secure the câbles using plastic ties with the aramids |
|---|--|

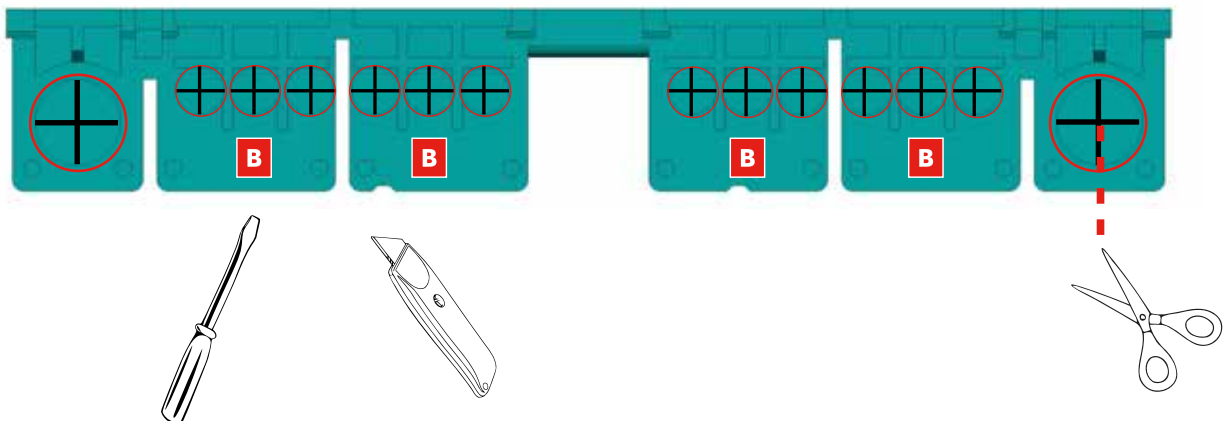

4x3 entrées de câbles sont disponibles pour les câbles de distribution **B**.

4x3 cable entries are available for distribution cables **B**.

8.2.1. Configuration câble microbundle *Microbundle cable configuration*

- | | |
|---|---|
| <ol style="list-style-type: none"> 1. Faire pivoter les cassettes pour accéder aux zones de lovage. 2. Le passage des tubes se fait en dessous du support et à l'extérieur du tambour 3. Lover les surlongueurs du câble secondaire sous les doigts de lovage situés à l'extérieur du tambour de lovage en passant par les volets. 4. Arrimer les tubes dénudés dans les peignes des cassettes. | <ol style="list-style-type: none"> 1. Rotate the cassettes to access the coiling areas. 2. The tubes routing made up below the organizer support and outside the drum. 3. Coil overlengths of the cable under the coiling legs located outside the coiling drum. Make sure cable are routed under all 4 (patching version) or 3 shutters. 4. Clamp the strip tubes on the combs of the cassettes. |
|---|---|



Les micromodules à raccorder doivent obligatoirement passer derrière le guide-câble pour éviter tout risque de pincement.

Before being connected, bundles must be routed behind the cable-guide to avoid any entanglement hazard.

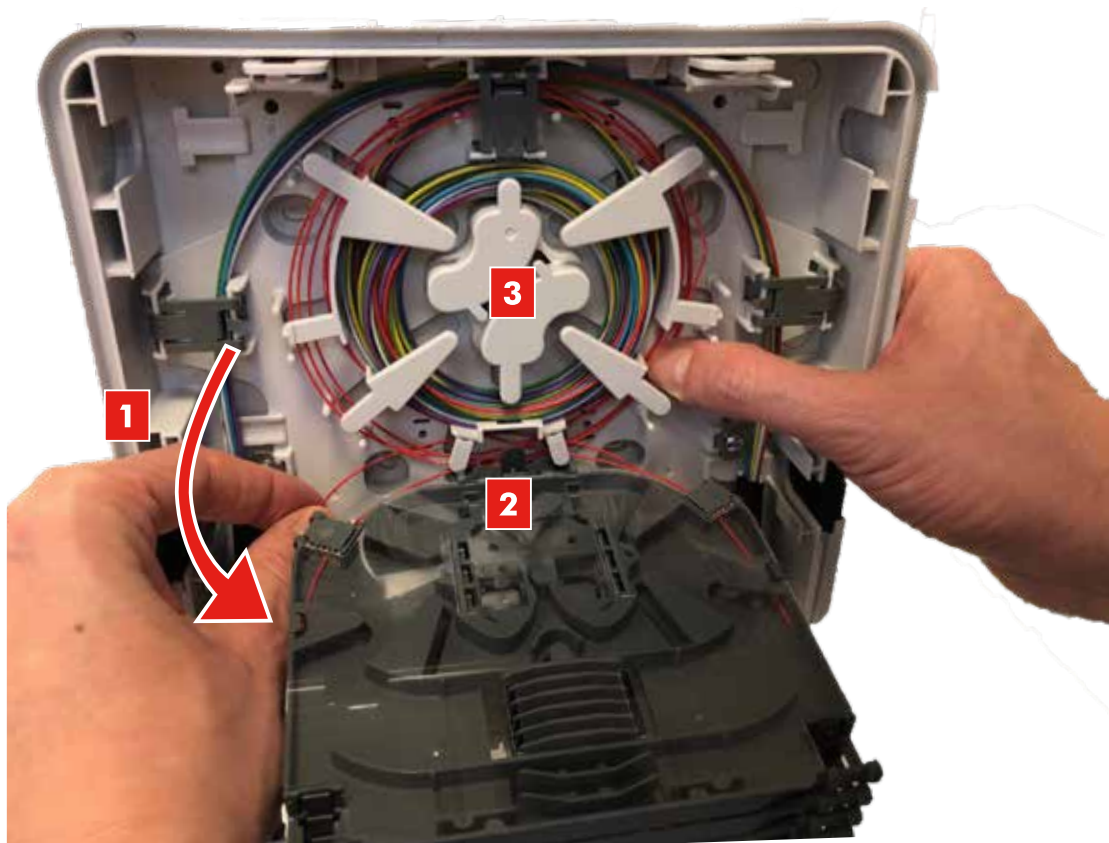

Le S du plateau de l'organiseur permet de faire un demi-tour des tubes .

The S of the coiling area allows to do an tubes halfturn

8.2.2. Configuration câble loose tube *Loose tube cable configuration*

- | | |
|---|--|
| <ol style="list-style-type: none"> 1. Faire pivoter les cassettes pour accéder aux zones de lovage. 2. Le passage des tubes se fait en dessous du support et à l'extérieur du tambour | <ol style="list-style-type: none"> 1. <i>Rotate the cassettes to access the coiling areas.</i> 2. <i>The tubes routing made up below the organizer support and outside the drum.</i> |
|---|--|

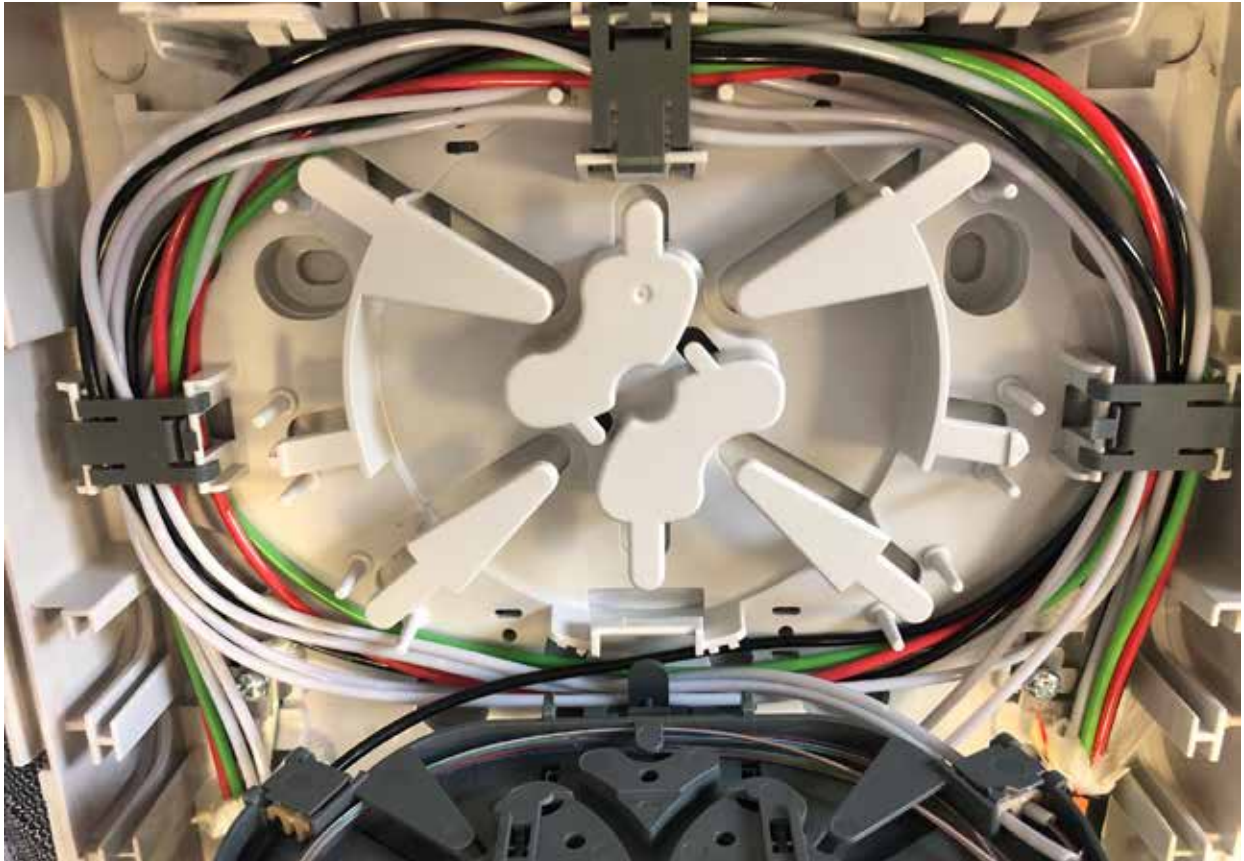

Afin de préserver l'intégrité des fibres optiques et d'éviter tout risque de torsion, détacher les pattes sécables du guide-câble.

To avoid any entanglement hazard and preserve the integrity of optical fibres, break the legs of the cable guide.

9. EPISSURAGE DES FIBRES SPLICING

- | | |
|--|---|
| <ol style="list-style-type: none"> 1. Procéder à l'épissurage des tubes dénudés. 2. Placer les protections d'épissures dans leur support. 3. Lover la surlongueur de la fibre nue dans la zone de lovage. | <ol style="list-style-type: none"> 1. Proceed to the splicing of striped tubes. 2. Secure the splicing supports on the splicing tray. 3. Coil the overlenght bare fibre in the coiling area. |
|--|---|

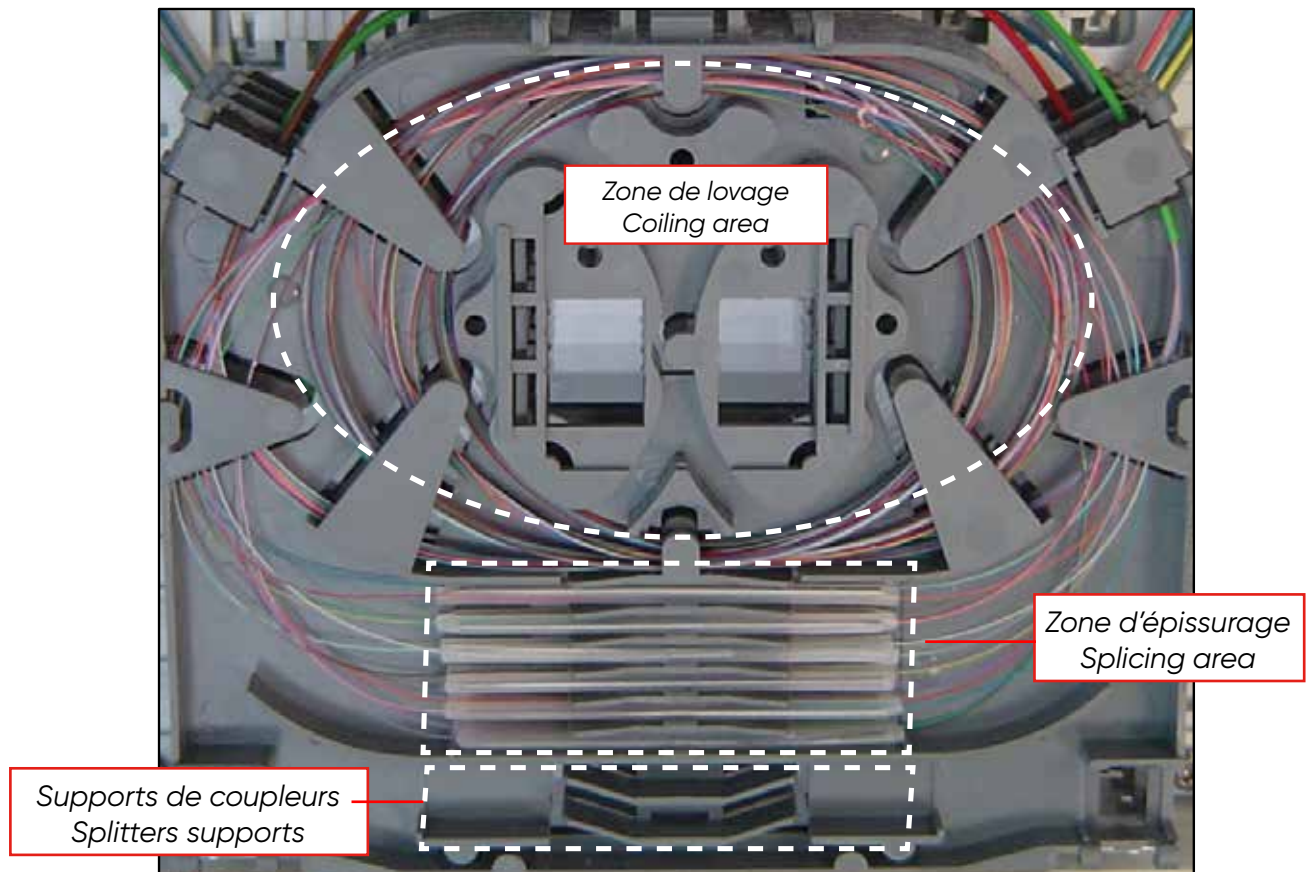

Fig. Epissurage des cassettes supérieure et inférieure
Splicing of upper and lower splicing trays

10. FERMETURE DU BOÎTIER
CLOSING THE DEVICE

10.1. Fermeture de l'organiseur
Closing the organiser



Les volets des cassettes d'épissure doivent être rabattus, et les supports de protection installés avant de fermer le boîtier.

Comb shutters must be closed, and protection covers installed on splice trays prior to closing the device.

Pour fermer l'organiseur, pousser délicatement les cassettes vers l'organiseur et les encliquer sur leur support de fixation.

To close the organizer, gently push the splice trays and clip them on their hinge.

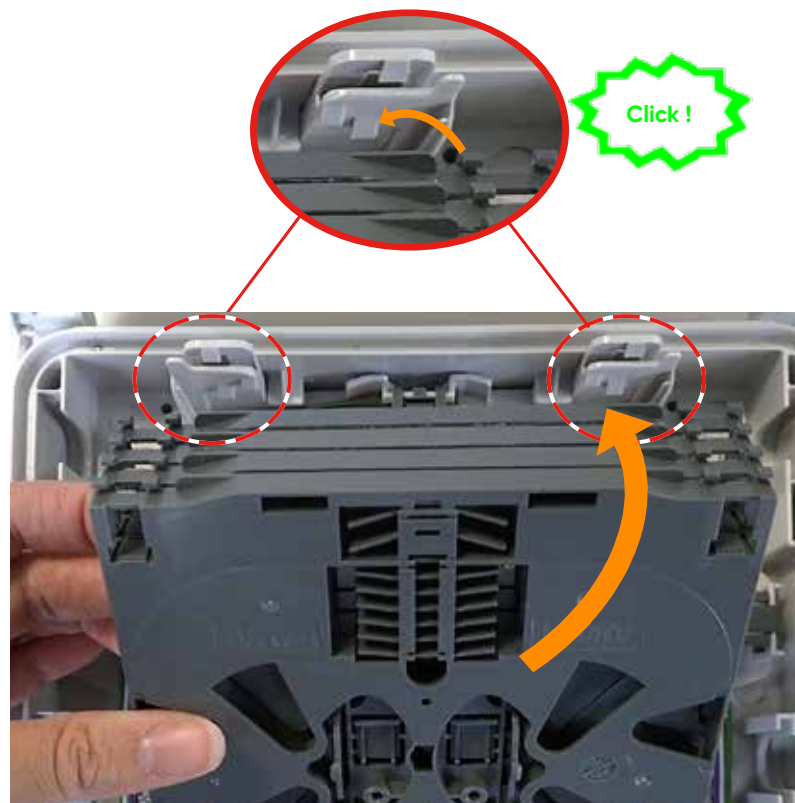

Fig. Fermeture de l'organiseur - version épissurage
Closing the organizer - splicing version

10.2. Réinstallation du capot *Reassembling the cover*

Dans le cas où le capot a été désinstallé, procéder comme indiqué ci-dessous :

If the cover has been removed from the device, proceed as follows:

- | | |
|---|--|
| <ol style="list-style-type: none"> 1. Incliner le capot à 35° environ, et aligner la partie droite du capot avec le socle. 2. Conserver cet angle et faire coulisser le capot vers la gauche pour enclencher la partie droite sur le boîtier. 3. Faire pivoter le capot vers le bas afin d'aligner la partie gauche du capot avec le reste du boîtier. 4. Faire pivoter le capot vers le haut afin d'achever la fixation du couvercle. 5. Fermer le boîtier. | <ol style="list-style-type: none"> 1. <i>Perform a 35° rotation on the cover, and align its right part with the device.</i> 2. <i>Keeping the 35° angle, gently slide the cover to the left to fit the right part on the device.</i> 3. <i>Perform a downward rotation to align the left part of the cover with the device.</i> 4. <i>Perform an upward rotation on the cover, to secure the cover on the device.</i> 5. <i>Close the device.</i> |
|---|--|

1

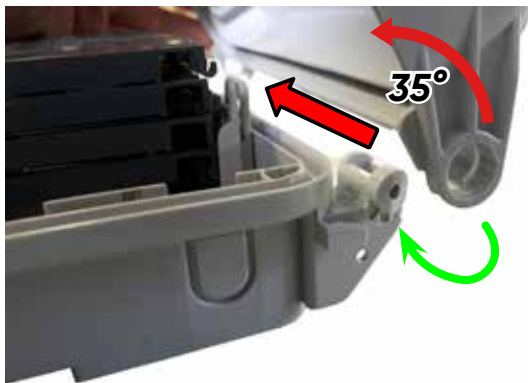

2

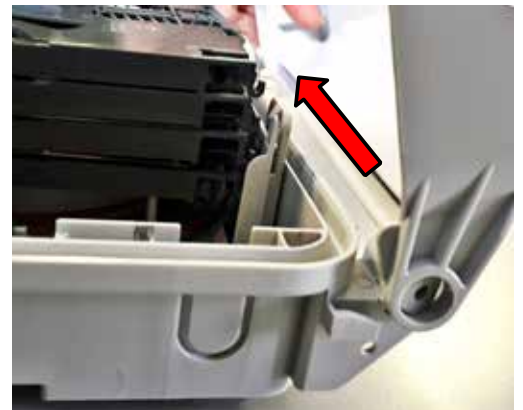

3

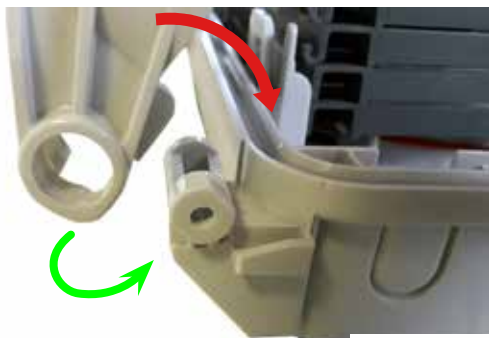

4



5



10.3. Fermeture du capot Closing the cover

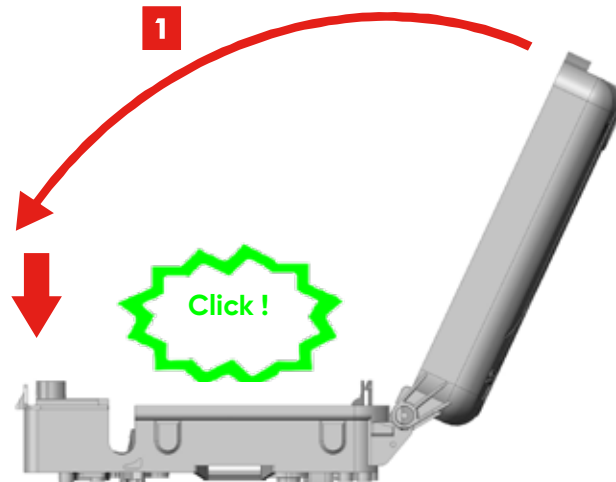

Pour les boîtiers ne disposant pas de serrure, la procédure se termine à l'étape 1.

If your device is not equipped with a lock, please proceed to step 1 only.

1. Rabattre totalement le capot et appuyer fermement dessus, jusqu'à l'émission d'un « clic ».
2. Utiliser une clé triangulaire 8 mm (non fournie) pour faire pivoter le 1/4 tour dans le sens horaire et verrouiller le boîtier.

1. Fully rotate the cover downwards, and apply tight pressure until a "click" is heard.
2. Use a 8 mm triangular key (not included) to operate a clockwise rotation and lock the device.



Fig. Fermeture du boîtier OutDrop 2+ Epissurage
Closing the OutDrop 2+ Epissurage device

11. INSTRUCTIONS DE FIN DE VIE
END LIFE INSTRUCTIONS

	 Emballage carton, sachet plastique <i>Cardboard, plastic packaging</i>	 Sachet zip réutilisable <i>Reusable zip bag</i>
	 Pièce métallique et plastique <i>Metal and plastic component</i>	WEEE / DEEE  Équipement électrique et électronique <i>Electrical and electronic equipment</i>



Se connecter via LinkedIn
Connect via LinkedIn

En savoir plus sur Youtube
Learn more on YouTube

Visiter www.aginode.net
Visit www.aginode.net

Contactez-nous via
Contact us via
info@aginode.net

AGINODE
25, avenue Jean Jaurès
08330 Vrigne-aux-Bois
FRANCE
Tel. +33 (0) 3 24 52 61 61